**TRAVEL TRAILER
AND
FIFTH WHEEL
OWNER'S MANUAL**

G U L F S T R E A M



COACH, INCORPORATED

Nappanee, Indiana

**GULF STREAMERS
INTERNATIONAL RV CLUB
APPLICATION – PAGE 43**



GULF STREAM COACH TRAVEL TRAILER AND FIFTH WHEEL OWNER'S MANUAL

Congratulations!

You are the proud owner of a new GULF STREAM, a remarkable recreational vehicle that has been engineered, tested and built in Indiana to meet your traveling and relaxation needs for many pleasurable years to come.

Many thousands of individuals have preceded you onto the highways of America, Canada and Mexico in GULF STREAM vehicles, enjoying the beauty of nature and the companionship of good people. Through personal contacts, both on the road and over the phone, GULF STREAM'S engineering and manufacturing staff has learned a lot about how our customers utilize their vehicles. We've put thousands of miles on our own test vehicles over the same roads many of our customers travel each year.

It's been our experience that if a customer plans well, follows the basic rules of the road and design limitations placed on their vehicle and its equipment, that they will enjoy thousands of carefree miles.

That's why we've included this Owner's Manual in your Owner's Packet along with the individual instruction booklets for all your appliances, and optional equipment. The more information you have available to you, the more you will get out of your new vehicle.

Please read over this manual and all the other owner's manuals included in your packet. It will make your initial trips in your new GULF STREAM much more pleasurable and save time in the long haul. Also, it is important that you complete the registration cards for each and every component and appliance included in this Gulf Stream product. Many component suppliers have extended repair coverage available and require that you register your components directly for coverage and recall notices.

Good traveling and good camping!

Sincerely,

GULF STREAM COACH, INC.
PO Box 1005
Nappanee, Indiana 46550

TABLE OF CONTENTS

GULF STREAM WARRANTY	4
COMPONENT WARRANTY COVERAGE AND SERVICE	6
LP GAS HEATING SYSTEM AND LP GAS APPLIANCE SAFETY REGULATIONS	7
GENERAL SAFETY	8
FIRE SAFETY.....	8
SMOKE DETECTOR.....	8
CARBON MONOXIDE SAFETY.....	8
LP GAS SAFETY.....	9
TOW VEHICLE REQUIREMENTS	9
BRAKE CONTROLLER.....	9
HITCHING – TRAVEL TRAILERS	9
EQUALIZING HITCHES.....	9
SWAY CONTROL.....	10
SAFETY CHAINS.....	10
HITCH LOCKING DEVICES.....	10
SAFETY BREAKAWAY SWITCH.....	10
POSITIONING THE HITCH BALL.....	10
HITCH HEIGHT ADJUSTMENT.....	11
HITCHING.....	11
UNHITCHING.....	11
HITCHING – FIFTH WHEELS	11
HITCHES.....	11
ELECTRICAL CONNECTION.....	12
SAFETY BREAKAWAY SWITCH.....	12
RIDE HEIGHT OF FIFTH WHEEL – CLEARANCE.....	12
VEHICLE LOADING	13
CARRYING CAPACITY.....	13
LOADING TIPS.....	13
WEIGHING YOUR TRAILER.....	14
TRAVEL TRAILERS – WEIGHING.....	14
FIFTH WHEELS – WEIGHING.....	15
MANUFACTURER’S LABELS.....	15
VEHICLE WEIGHT INFORMATION LABEL.....	16
FEDERAL WEIGHT DEFINITIONS.....	16
TIRES	16
TIRE MARKINGS.....	16
TIRE LOAD RATINGS.....	17
TIRE AIR PRESSURE.....	17
TIRE MAINTENANCE.....	17
WHEEL NUT TORQUE.....	17
ELECTRIC BRAKE SYSTEM.....	18
TRAVEL TRAILER “HOUSE” SYSTEMS	18
SAFETY.....	18
ELECTRICAL.....	19
12-VOLT/110-VOLT.....	19
30-AMP AND 50-AMP 110-VOLT SERVICE.....	19
POWER CONVERTER.....	20
GROUND FAULT INTERRUPTER.....	21
BATTERY.....	21
BATTERY TYPES AND CHARGING.....	22
MONITOR PANEL.....	22
TV ANTENNA AND CABLE CONNECTIONS.....	22
RAISING AND LOWERING TV ANTENNA.....	23
LP GAS	23
GENERAL.....	23
CLIMATE DIFFERENCES.....	24

OPERATION.....	24
FILLING THE LP TANK.....	24
GAS LINE CHECK.....	24
REGULATOR PRESSURE.....	25
GAS TANK AND REGULATOR FREEZE UP.....	25
HOSE REPLACEMENT.....	25
REGULATOR VENT MAINTENANCE.....	25
PLUMBING	25
FRESH WATER.....	25
CITY WATER.....	26
WATER TANK.....	26
WATER SYSTEMS CONVENIENCE CENTER.....	26
SANITIZING THE WATER TANK.....	26
WATER PUMP.....	27
SECONDARY WATER PUMP SWITCH.....	27
WINTERIZING THE WATER PUMP.....	27
DRAINAGE AND SEWER.....	27
DRAINAGE P-TRAPS.....	28
HOLDING TANKS.....	28
EMPTYING HOLDING TANKS.....	28
HOLDING TANK MAINTENANCE.....	29
DO'S AND DON'TS OF HOLDING TANK USE.....	29
HOLDING TANK FLUSH SYSTEM.....	29
WATER SYSTEM WINTERIZING.....	29
APPLIANCES	30
WATER HEATER.....	30
RANGE.....	31
MICROWAVE.....	31
REFRIGERATOR.....	31
FURNACE.....	31
AIR CONDITIONER.....	32
FANTASTIC FAN OPERATION.....	32
EFFECTS OF LONG TERM OCCUPANCY	33
FORMALDEHYDE.....	33
CONDENSATION AND MOLD.....	34
SLIDE OUT SYSTEMS	34
SLIDE OUT MANUALS AND TROUBLESHOOTING.....	34
SLIDE OUT BREAKER SWITCH.....	34
SLIDE OUT WEATHER SEALS.....	35
AWNINGS	35
ELECTRIC AWNINGS.....	35
MANUAL AWNINGS.....	35
MAINTENANCE	36
ROOF.....	36
RUBBER ROOF REPAIR.....	36
ALUMINUM EXTERIOR SKIN.....	36
SIDEWALL TRIM AND COMPONENTS SEALANTS.....	36
PAINT, FIBERGLASS AND SIDEWALL CARE.....	37
CORROSION PROTECTION.....	37
AWNING CARE.....	37
REPORTING SAFETY DEFECTS	37
PRE-TRIP CHECKLIST	38
MAINTENANCE SCHEDULE	39
TRAILER LIGHT AND ELECTRIC BRAKE WIRING SCHEMATIC	40
INDEX	41
GULF STREAMERS INTERNATIONAL RV CLUB APPLICATION	43

GULF STREAM WARRANTY AND WARRANTY SERVICE

GULF STREAM COACH, INC. LIMITED WARRANTY

IN THE UNITED STATES AND CANADA

For Your Protection And Understanding, Read All Parts Of This Limited Warranty And All Other Warranties Furnished With This Recreational Vehicle.

1. WHAT IS COVERED

A new Gulf Stream Coach, Inc. ("Gulf Stream") recreational vehicle has a limited warranty by Gulf Stream to the initial retail purchaser under normal use, when sold by an authorized Gulf Stream dealer and used for its intended purpose for recreational travel and camping as follows:

- a) A one (1) year warranty under normal use against defects in Gulf Stream materials and/or workmanship in the construction of the recreational vehicle.
- b) A two (2) year warranty under normal use against structural defects in Gulf Stream materials and/or workmanship in the construction of the floors, walls and roof.

The warranty coverage starts on the date the initial retail purchaser takes possession of such recreational vehicle. This Limited Warranty covers only those defects which occur or exist within the applicable period(s) referenced above and which are specifically identified to Gulf Stream in the manner specified in Section 4 of this Limited Warranty. **All obligations of Gulf Stream pursuant to this Limited Warranty are limited to replacing or repairing the defective part or component.**

2. DISCLAIMER OF WARRANTIES

This Limited Warranty is expressly IN LIEU of any other express warranty and is further IN LIEU of any implied warranty, including, but not limited to, any implied WARRANTY OF MERCHANTABILITY or FITNESS for a particular purpose. To the extent that applicable state and/or federal law prohibits the exclusion of any remedy permitted under state or federal law, any such remedy, including, but not limited to, implied warranties of fitness, use, merchantability or purpose, is limited to one (1) year from the date the initial retail purchaser takes delivery of the recreational vehicle.

3. WHAT ARE THE INDEPENDENT DEALER'S OBLIGATIONS

It is the responsibility of the independent dealer ("dealer") to maintain the recreational vehicle until retail sold; to perform a comprehensive pre-retail delivery check procedure and inspection; to repair or replace any defective parts; to correct defects in workmanship which are identified prior to initial retail purchaser's taking delivery of the recreational vehicle; to present the initial retail purchaser with this Limited Warranty prior to the initial retail purchaser's entering into any written contract to purchase a recreational vehicle; and to mail to Gulf Stream the signed Gulf Stream Recreational Vehicle Registration Form and the signed Limited Warranty.

4. WHAT ARE THE PURCHASER'S OBLIGATIONS

The Purchaser is responsible for all maintenance as described in the Gulf Stream Owner's Manual and/or any other care and maintenance manual supplied with the recreational vehicle; however, minor adjustments (such as adjustments to the interior or exterior doors, LP regulator pressure, cabinet latches, TV antenna control, etc.) will be performed by the dealer during the first 90 days of warranty coverage only. Thereafter, such adjustments are the responsibility of the Purchaser as normal maintenance unless required as a direct result of repair or replacement of a defective part under this Limited Warranty.

If an issue occurs which the Purchaser believes is covered by this Limited Warranty, Purchaser is responsible to promptly contact Gulf Stream by certified mail, return receipt requested, giving specific notice of the issue(s) being experienced with the recreational vehicle. Such notice must be addressed to the National Retail Service Manager, Gulf Stream Coach, Inc., P.O. Box 1005, Nappanee, Indiana 46550, and must be received by Gulf Stream within the earlier of 30 days after the issue is known to the initial retail purchaser or 10 days subsequent to the expiration of this Limited Warranty. After proper notification has been received by Gulf Stream Coach, Inc., failure of Purchaser to initiate prompt service of repairs approved by Gulf Stream within 30 days of approval WILL VOID ANY CLAIM FOR SUCH DEFECT OR DAMAGE.

Gulf Stream will arrange for repair or replacement, as determined by Gulf Stream, of Gulf Stream parts or workmanship identified as defective by Gulf Stream and such parts replaced shall become property of Gulf Stream. Gulf Stream is ready, willing and able to make every effort for a quick response. If for any reason the recreational vehicle is out of service, or is anticipated to be out of service for a cumulative total of seven (7) days during the applicable warranty period, regardless of whether the cause of such out of service time is covered by this Limited Warranty, the Purchaser is to immediately contact Gulf

Stream by certified mail, return receipt requested, setting forth the service issue(s). Gulf Stream reserves the right to cure all warranty claims. Service work conducted by any party not specifically authorized by Gulf Stream to undertake such work is specifically not covered by this Limited Warranty and WILL VOID THIS LIMITED WARRANTY. Further, failure of the Purchaser to comply with the notification provisions of this section WILL VOID THIS LIMITED WARRANTY.

The Purchaser must maintain all evidence of any defect or damage through the ultimate resolution of any claim and make such evidence available to Gulf Stream. Failure to preserve such evidence will VOID ANY CLAIM FOR SUCH DEFECT OR DAMAGE.

5. WHAT IS NOT COVERED BY LIMITED WARRANTY

- **This Limited Warranty does not apply to any vehicle sold to the initial retail purchaser more than two years after shipment to the authorized Gulf Stream selling dealer.**
- **The automotive systems including, but not limited to, tires, wheels, batteries, the chassis and drive train and any part of that chassis included/supplied by the chassis manufacturer.**
- **Appliances and component parts not manufactured by Gulf Stream, including, but not limited to, auxiliary generator power plants, refrigerators, air conditioners, water heaters, furnaces, invertors, etc.**
- **Failure which may be caused by, or related to abuse, misuse, negligence, or accident; failure which may be related to alteration(s) or modification(s), failure as a result of not following instructions contained in the Gulf Stream owner's manual and/or any other care and maintenance manual supplied with the recreational vehicle.**
- **Deterioration due to wear or exposure, such as fading of fabrics or drapes, carpet wear, exterior surfaces, etc.**
- **Maintenance items, including, but not limited to, light bulbs, fuses, wiper blades, lubricants, minor adjustments, wheel alignments.**
- **Use of the recreational vehicle for any commercial or rental purpose voids the warranty from the time that the vehicle is first used for a commercial or rental purpose and at all times thereafter.**
- **Motor homes on which the odometer reading has been altered.**
- **Transportation to and from dealer, service center or manufacturing plant location, nor any consequential and/or incidental expenses such as, but not limited to, loss of time, commercial loss, loss of use, towing charges, lodging, food, phone calls, inconvenience, bus or plane fares, rental charges or storage fees.**
- **Any defects or shortages at the time of delivery to the Purchaser unless noted on the *driver and dealer acceptance form* or the *driver evaluation sheet*.**
- **Non-structural defects in the exterior fiberglass sidewall panels, including, but not limited to, checking, crazing, cracking, chalking and/or porosity.**
- **Any component part which possesses its own warranty from a party other than Gulf Stream.**
- **Loss or damage caused by insurrection, riot, or act of the public enemy, loss or damage caused by forces of nature, including but not limited to, flood, wind, storm, hurricane, tornado, blizzard, explosion, or fire.**

6. IMPORTANT FACTS

- The Purchaser must inspect the recreational vehicle at the time of delivery to ensure that it is acceptable as delivered. This recreational vehicle has been sold to an independent dealer, and not an agent of Gulf Stream, for resale in the ordinary course of the dealer's business, on terms and conditions and equipped as the dealer and the initial retail purchaser determine, and the initial retail purchaser's agreement is solely with the dealer, not Gulf Stream. Gulf Stream does not participate in retail sales or retail contracts.
- Gulf Stream reserves the unrestricted right at any time and from time to time to make changes in the design of and/or improvements upon its recreational vehicles without thereby imposing any obligation upon itself to make corresponding changes or improvements in or upon its recreational vehicles already manufactured. Gulf Stream further reserves the right to substitute parts or components of substantially equal quality in any warranty service required by operation of this Limited Warranty.
- Like any other product, a recreational vehicle and the products installed in it will require care and maintenance attention by the owner and occupants. Please read and follow all care and maintenance manuals, warning labels, safety notices and instructions supplied with the recreational vehicle.
- Authorized dealers and service centers are independent contractors and independently owned businesses. This is also true of the authorized chassis dealers and service centers.

7. JURISDICTION AND APPLICABLE LAW

Exclusive jurisdiction for deciding any claims, demands or causes of action for defects or representations of any nature or damages due from such defects or representations shall be in the courts in the State of Manufacture. The laws applicable to any litigation, dispute, mediation, arbitration or any claim whatsoever arising from the sale, purchase, or use of the recreational vehicle shall be those of the State of Manufacture. The State of Manufacture of the recreational vehicle is Indiana.

This Limited Warranty gives Purchaser specific legal rights and the Purchaser may also have other rights that may vary from state to state. Gulf Stream is not responsible for any representation or warranty that is not herein stated unless required by applicable state or federal law. Some states may prohibit certain exclusions from express warranty coverage, and/or the exclusion of remedies and implied warranties. Some states do not allow limitations on how long the Purchaser's remedies are available or an implied warranty lasts, so, to the extent applicable state law permits a remedy or an implied warranty obligation on the part of Gulf Stream, the above limitation of remedies stated in Section 2 may not apply. Some states do not allow the exclusion or limitation of damages, so, to the extent applicable state law does not permit such limitation or exclusion, the limitation and exclusions set forth in Section 2 above may not apply. Consult your personal attorney to determine all rights under the state and federal consumer laws, which may offer remedies in addition to or different from this Limited Warranty.

I/WE HEREBY ACKNOWLEDGE THAT I/WE HAVE READ AND RECEIVED THIS LIMITED WARRANTY PRIOR TO ENTERING INTO ANY CONTRACT TO PURCHASE MY/OUR GULF STREAM RECREATIONAL VEHICLE AND AGREE TO ABIDE BY ALL OF ITS TERMS AND PROVISIONS INCLUDING, BUT NOT LIMITED TO, THE DISCLAIMER OF ALL OTHER EXPRESS AND IMPLIED WARRANTIES, INCLUDING ANY IMPLIED WARRANTY OF MERCHANTABILITY OR FITNESS FOR A PARTICULAR PURPOSE, TO THE EXTENT APPLICABLE LAW ALLOWS, AND THE PROVISIONS HEREOF PROVIDING THAT THE EXCLUSIVE JURISDICTION FOR ANY CLAIMS WHATSOEVER SHALL BE IN THE COURTS IN THE STATE OF MANUFACTURE AND THAT THE APPLICABLE LAW SHALL BE THE LAW OF THE STATE OF MANUFACTURE.

WARRANTY SERVICE

1. Warranty service, under your Limited Warranty, is to be performed by your authorized Gulf Stream dealer from whom you purchased your unit or by an authorized service center for those appliances and equipment not maintained by Gulf Stream. Your dealer has a vested interest in your satisfaction, therefore, if at all possible; it is best to return to your dealer for service.
2. If you are traveling or move, any authorized dealer may provide service. Keep your warranty registration form with the vehicle at all times since it must be presented for warranty service. This form is your proof of purchase and provides the date of retail sale, both of which are necessary to determine warranty eligibility.
3. If you cannot locate an authorized Gulf Stream dealer contact: **GULF STREAM COACH, INC.**
PO Box 1005
Nappanee, IN 46550
1.800.482.6456
4. Other warranties - The retail customer is responsible for completing and forwarding warranty registration cards/forms for all items not covered by either the chassis manufacturer's or Gulf Stream's warranty.
5. **YOUR WARRANTY IS NOT VALID UNTIL IS HAS BEEN SIGNED AND SUBMITTED TO GULF STREAM COACH, INC!**

Your authorized Gulf Stream Dealer from whom you purchased your unit will assist you in service, maintenance, selection of options, and instructions concerning the operation of your recreational vehicle. Occasionally, a warranty or service matter may not be handled to your satisfaction. In this case, we recommend that you discuss the problem with dealer management. If you are unable to find satisfaction at the dealer level, please contact the Gulf Stream Service Department, where we will make our best effort to reach an agreeable solution. In most instances, we will eventually refer you back to the local dealer with our recommendations.

COMPONENT WARRANTY COVERAGE AND SERVICE

Your Gulf Stream product comes equipped with many components that have their own warranty. Although repair of these components is usually done through an authorized recreational vehicle dealer, it is important that you complete the registration cards for each and every component and appliance included in this Gulf Stream product. Many component suppliers have extended repair coverage available and require that you register your components directly for coverage and recall notices. Please do not delay in returning all registrations cards directly to the respective component manufacturer (refrigerator, air conditioner, water pump, water heater, furnace, rubber roof, etc.).

LP GAS HEATING SYSTEM AND LP GAS APPLIANCE SAFETY REGULATIONS

The United States Government requires that the manufacturer of this recreational vehicle provide the following safety information that has been provided by the National Fire Prevention Association (NFPA) and the American National Standards Institute (ANSI). The information contained below will also be found, along with additional information, in other appropriate sections of this operator's manual. Refer to the Table of Contents and the Index.



WARNING: LP-Gas cylinders shall not be stored inside the vehicle. LP-Gas cylinders are equipped with safety devices that relieve excessive pressure by discharging gas to the atmosphere. FAILURE TO COMPLY COULD RESULT IN DEATH OR SERIOUS INJURY.

A warning label has been located near the LP-Gas container. This label reads as follows.

DO NOT FILL CONTAINER(S) TO MORE THAN 80 PERCENT OF CAPACITY.

1. Overfilling the LP-Gas container can result in uncontrolled gas flow, which can cause fire or explosion.
2. A properly filled container will contain approximately 80 percent of its volume as liquid LP-Gas.



WARNING: IT IS NOT SAFE TO USE COOKING APPLIANCES FOR COMFORT HEATING.

1. Cooking appliances need fresh air for safe operation.
Before operation:
 - (a) Open the overhead vent or turn on the exhaust fan.
 - (b) Open a nearby window.
2. Unlike homes, the amount of oxygen supply is limited due to the size of the recreational vehicle, and proper ventilation when using cooking appliance(s) will avoid the dangers of asphyxiation. It is especially important that cooking appliances not be used for comfort heating, as the danger of asphyxiation is greater when the appliance is used for long periods of time. **FAILURE TO COMPLY COULD RESULT IN DEATH OR SERIOUS INJURY.**



WARNING: Portable fuel-burning equipment, including wood, charcoal grills and stoves, shall not be used inside the recreational vehicle. The use of this of this equipment inside the recreational vehicle can cause fires and asphyxiation.



WARNING: Do not bring or store LP-Gas cylinders, gasoline or other flammable liquids inside the vehicle because a fire or explosion can result.

The following label has been placed in the cooking area of the vehicle:

IF YOU SMELL GAS:

1. Extinguish any open flame, pilot light and smoking material.
2. Do not touch electrical switches.
3. Shut off the LP gas supply at the tank valve(s) or gas supply connection.
4. Open doors and other ventilating openings.
5. Leave the area until the odor clears.
6. Have the gas system checked and leakage source corrected before using again.

LP gas regulators must always be installed with the regulator vent facing downward. Regulators that are not in compartments have been equipped with a protective cover. Make sure that the regulator vent faces down and that the cover is kept in place to minimize vent blockage that could result in excessive gas pressure causing fire or explosion.

Notice: All LP gas regulators are factory tested for proper pressure output. Pressure output should be checked periodically by a qualified LP dealer. Only qualified persons should install, adjust or service LP gas regulators. If service is needed contact a qualified LP dealer.

GENERAL SAFETY

FIRE SAFETY

Prevention is the best form of fire safety. Carefully follow the instructions for the care and operation of the various appliances in your vehicle (see appropriate sections).

Follow the same basic rules of fire prevention that you use at home. **DO NOT SMOKE IN BED. DO NOT OVERLOAD THE ELECTRICAL SYSTEM. DO NOT PERMIT CHILDREN NEAR THE LP GAS CONTROLS OR CONTAINER. DO NOT STORE FLAMMABLE LIQUIDS INSIDE THE UNIT.**

Carry-over your fire preparedness from home to your RV by having a pre-planned escape route. **BE SURE EVERYONE KNOWS WHERE THE EMERGENCY EXITS ARE LOCATED AND HOW THEY OPERATE.**

Your RV has been equipped with a fire extinguisher. **MAKE SURE EVERYONE KNOWS WHERE IT IS LOCATED, HOW TO OPERATE IT AND WHAT TYPES OF FIRES IT IS DESIGNED TO HANDLE.**

Check the extinguisher on a regular basis to make sure it is charged.

SMOKE DETECTOR

All units are equipped with a smoke detector. Check its operation on a regular basis. If it does not check properly, get it serviced or replaced prior to using the coach again.

NOTE: IF A FIRE DOES START WITHIN THE UNIT, GET ALL OCCUPANTS OUT IMMEDIATELY. IF IT IS A SMALL FIRE, USE THE FIRE EXTINGUISHER. IF THE FIRE IS NOT QUICKLY PUT OUT, GET OUT OF THE VEHICLE. CONTACT THE FIRE DEPARTMENT. IF POSSIBLE, CLOSE THE LP GAS SERVICE VALVE. MOVE A SAFE DISTANCE FROM THE VEHICLE.

CARBON MONOXIDE SAFETY

Carbon Monoxide is a colorless, odorless, tasteless gas, which can be fatal if a high concentration builds up in a sealed area over a period of time. Carbon Monoxide is a by-product of burning fuel, and is found in high concentrations in exhaust from gas burning engines. A water heater or furnace operating improperly can also produce Carbon Monoxide. Under normal conditions your coach should be free from Carbon Monoxide at any given time. Due to the safety hazards of Carbon Monoxide (CO), each Gulf Stream motor home is equipped with a CO Detector.

Carefully read the instructions included with your CO detector to ensure proper use and maintenance. Most CO detectors require only occasional dusting and weekly testing. **DO NOT** use any type of cleaner when dusting your CO detector. Doing so may render the unit useless without warning.

Carbon Monoxide is often confused with illness such as "flu like symptoms". (Headaches, Nausea, Dizziness). Such symptoms should be discussed with all vehicle occupants. RV certified CO detectors will sound an alarm if 100 PPM (parts per million) of CO is present within 90 minutes. 50 PPM is allowed in a work place for up to 8 hours. Cigarette smoke contains about 5 PPM Carbon Monoxide.

If your CO alarm sounds, exit the vehicle immediately. After exiting the vehicle take a head count and make sure everyone is accounted for. Air out the vehicle and check again to ensure that the alarm came from the CO detector, as your vehicle is also equipped with a smoke detector and LP gas detector (optional). Following instructions included with your CO detector is recommended.

LP GAS SAFETY



WARNING: SHUT OFF ALL LP GAS SYSTEMS BEFORE FILLING THE GASOLINE TANK. LP appliances should never be operated while the vehicle is in motion. If the pungent odor of LP gas is detected, immediately shut off the LP gas valve and check the LP gas label for further instructions. Your unit may be equipped with an LP gas leak detector that will help you detect the presence of LP gas. However, this detector should not be relied upon solely; if you detect the smell of LP gas, shut off the gas valve immediately. Check other sections of this manual for more information on the LP gas system.

TOW VEHICLE REQUIREMENTS

Prior to hitching and pulling your travel trailer or fifth wheel, make sure your tow vehicle is properly suited and equipped for such use. Read your tow vehicle's owner's manual sections on trailer towing, Gross Combined Weight Rating, hitch requirements, sway control requirements, braking requirements, and all related areas for proper towing. Gulf Stream Coach, Inc. is not responsible for problems associated with insufficient towing capabilities of the tow vehicle or hitching systems. Make sure your hitch is rated for the amount of weight you are towing when fully loaded.

BRAKE CONTROLLER

All Gulf Stream travel trailers and fifth wheels are equipped with electric brakes due to the weight of the trailer. This requires your tow vehicle to have an electronic brake controller installed to control and adjust the trailer brakes.

There are several different manufacturers of brake controllers. Each controller has adjustable settings that could provide safe, effective stopping or lockup your trailer brakes upon use, depending on the settings selected. It is required that you read the instruction manual for the brake controller and learn about its proper use prior to pulling your Gulf Stream travel trailer or fifth wheel.

Consult with your dealer on which brake controller is recommended for your tow vehicle/trailer combination.



WARNING! TEST YOUR TRAILER BRAKES WITH YOUR BRAKE CONTROLLER PRIOR TO EACH TRIP TO ENSURE ITS PROPER OPERATION!

HITCHING – TRAVEL TRAILERS

EQUALIZING HITCHES

In addition to the pulling weight of a trailer, a tow vehicle must also support approximately 9-15% of the actual weight of the trailer at the hitch point. With a 6,000 lb. trailer, this additional weight might be 700 to 800 lbs. This much weight added to your rear bumper could cause the car to become out of balance, and traction on the front wheels to be reduced. This may result in poor steering control, poor braking control, and can be potentially dangerous. Use of heavier springs, spring helpers or stiffer tires will not correct the basic out-of-balance condition. The problems from this condition are compounded when traveling over bumps and dips in the road. The balance problem is solved by the addition of a suitable matched "equalizing hitch," sometimes called a "weight distributing hitch." Basically, the affect of an equalizing hitch is to distribute the hitch load equally between the front and rear tow vehicles axles and the trailer axle(s) (see figure on page 10). If the weight at the hitch is 450 lbs., the affect of the equalizing hitch would be to distribute this weight in approximately equal portions to both tow vehicle axles and all trailer axles. Thus, your tow vehicle can remain relatively level. This not only will give you better steering and brake control, but also will insure that your headlight beams remain down on the road where they belong. Equalizing hitches also afford help in sway control.

Most hitch manufacturers offer equalizing hitches in several sizes designed to handle trailers of various hitch-weight classes. Get the hitch size that is right for your requirements. Your dealer will help you select one on the basis of your trailer weight and tow vehicle. Improperly sized equalizing hitches can damage your trailer frame.

Please consult your tow vehicle's owner's manual for requirements on using load equalizing hitches.

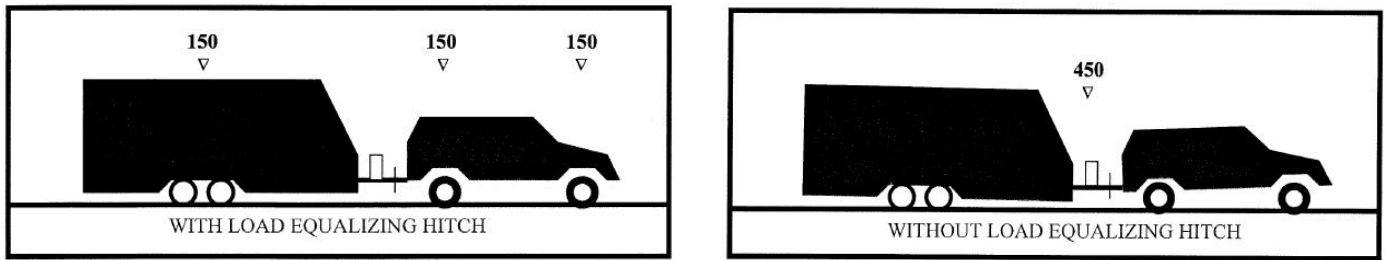

EQUALIZING HITCH LOAD COMPARISON

SWAY CONTROL

Except for the very light folding tent campers, most trailers should employ some type of sway control device. There are several types of these devices available, operating on different principles such as friction, cam action, and computer operated braking of the trailer wheels. Each has its advantages. They will all decrease or eliminate the sway affects induced by passing trucks, strong winds, and down-hill grades. They will make your towing safer when driving under adverse conditions.

Please consult your tow vehicle's owner's manual for requirements on using sway control devices.

If you encounter a situation where the trailer is swaying, accelerate slightly then gradually slow down, do not "hit" the brakes. If your trailer still sways, slowly pull off the road and check your weight distribution hitch, then your tow vehicle and trailer tire pressures.

SAFETY CHAINS

There are different safety chain requirements in the various states. As delivered by your dealer, your trailer is equipped to meet the state requirements where purchased. Heavier and/or additional chains with case-hardened, quick-connect links may be desired. Always have the safety chains attached when towing. Install them in a manner so they do not restrict sharp turns of the tow vehicle, but tight enough so they do not drag on the ground.

HITCH LOCKING DEVICES

Make sure that locking devices and/or safety pins are in place before beginning your travels. Your failure to secure the hitch may be costly. If your hitch utilizes a pin for securing the safety latch, carry a spare.

SAFETY BREAKAWAY SWITCH

A stand-alone battery or the auxiliary 12 volt battery powers safety breakaway switches for the RV. If the trailer becomes detached while towing, the pin is pulled out and current is applied to the trailer brakes automatically. Occasionally pull the pin out and check the braking action. Make sure your battery is kept well charged for this emergency braking circuit.

POSITIONING THE HITCH BALL

The hitch ball should be installed as close to the tow vehicle bumper as possible, without limiting the turning radius of the combination of vehicles. Locating the hitch ball too far to the rear puts a greater strain on the equalizer spring bars and decreases stability when encountering side winds or gusts from large trucks.

HITCH HEIGHT ADJUSTMENT

If the spring bars on the equalizer hitch are fitted with chains for fastening to the trailer “A” frame, the selection of the proper link to be used at the connecting point can best be chosen by “hitching up” on a level road or driveway. After hitching up the trailer visually inspect how level the tow vehicle/trailer combination is and adjust the chain link selection accordingly. In order to have a level tow vehicle/trailer combination you may have to raise or lower the hitch ball on the tow vehicle. Most, if not all, equalizer hitches allow for height adjustments of the hitch ball.

Remember which chain link is used on the equalizer hitch spring bar for your most common load conditions. This will save time in future use! Depending on the trailer load each time the trailer is used, you may have to go up or down one link to have a level tow vehicle/trailer combination.

HITCHING

Before starting the hitching operation, remove (or raise) the stabilizing jacks (if equipped) from beneath the trailer. Make sure the coupler on the trailer “A” frame is in the “unlatched” position. With another person as a guide, back the tow vehicle hitch ball under the coupler and lower the coupler over the hitch ball. Latch the coupler and install the safety pin immediately before any other steps are taken. Attach the equalizing hitch spring bars, the safety chains, safety breakaway switch tether and the electric connection plug. Crank the trailer jack all the way up and remove the wheel chocks from the trailer wheels. Before starting down the road, check the trailer lights and brake operation.

UNHITCHING

The site for parking your trailer should be as level as possible so less jacking will be necessary to level the trailer. The ground should also be firm enough that the jacks will not sink.

Before unhitching, the trailer should be immobilized by use of wheel chocks placed both in front of and behind the wheels on both sides of the trailer. This is important to keep the trailer from moving downhill if the site is not exactly level.

After removing the safety chains, the breakaway switch tether and the trailer electrical plug, place a block under the hitch jack and extend the jack to meet it firmly, and raise the hitch a few inches with the coupler and equalizer hitch still attached to the hitch ball. This will remove pressure on the equalizer hitch. Next, carefully remove the equalizer hitch spring bar in accordance with the hitch manufacturer’s instructions. Lower the hitch back down to where it barely has pressure on the ground. The safety latch on the hitch coupler should now be released and the hitch jacked back up until it just clears the hitch ball. With all hitch items detached, you can now remove the tow vehicle and proceed to level the trailer. Remember that such leveling is not only important to your comfort, but also for proper functioning of the refrigerator and the plumbing drain lines.

HITCHING – FIFTH WHEELS

HITCHES

There are several types of fifth wheel hitches available. Be certain to use the one recommended by your vehicle manufacturer and that meets the weight requirements of your fifth wheel. The one described here is typical (FIG 1), but have your dealer demonstrate and explain the proper hitching and unhitching procedure for your hitch.



NOTE! MAKE SURE YOUR FIFTH WHEEL HITCH IS INSTALLED IN A LOCATION THAT ALLOWS PROPER TURNING CLEARANCE OF THE FIFTH WHEEL AND THE TRUCK CAB!

To hitch the fifth wheel, lower or remove the tailgate. Release the plate jaws by pulling the handle. It may be necessary to raise or lower the fifth wheel with the front jacks to align the pin with the jaw plates. Once connected, put your truck in drive and apply pressure on the hitch to ensure it is locked. Then activate your electric jacks or turn the crank jack to raise the jacks off the ground as far as possible

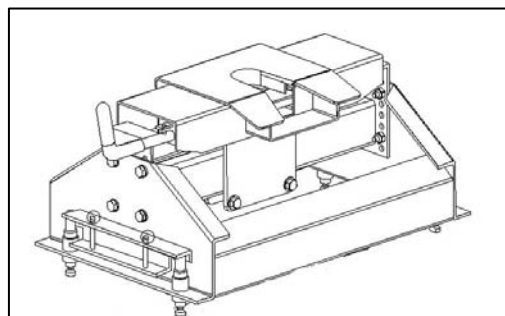

FIFTH WHEEL PLATE (FIG. 1)



WARNING: DO NOT CHANGE OR MODIFY THE PIN BOX INSTALLED ON YOUR FIFTH WHEEL FRAME. DO NOT USE A “GOOSE NECK” TYPE HITCH AND PIN PLATE ON YOUR FIFTH WHEEL. GULF STREAM DOES NOT USE ANY FRAME DESIGNED FOR GOOSE NECK HITCHES. THESE TYPES OF HITCHES WILL DAMAGE YOUR FRAME AND VOID YOUR WARRANTY!

ELECTRICAL CONNECTION

Plug the pigtail on the fifth wheel or travel trailer into the electrical harness on the truck. Be sure there is enough slack to allow the vehicle to turn without disconnecting the pigtail. Make sure all lights and the brakes work prior to moving the fifth wheel or travel trailer. For pigtail wiring information on this trailer, please see page . For proper trailer wiring on your tow vehicle, please refer to your tow vehicle’s owner’s manual.

SAFETY BREAKAWAY SWITCH

Attach the safety breakaway tether to the truck body. DO NOT attach the cable to the plate handle, hitch plate base or plate mounting brackets. Adjust the cable so both vehicles may turn freely without pulling the pin from the switch. Lubricate the breakaway pin periodically to ensure good operation. Make sure the pin is securely in place each time before using the trailer. The tow vehicle battery will supply power for the safety breakaway switch pin if a separation occurs. However, if the pigtail also disconnects, the fifth wheels brakes will not engage unless an RV battery is installed in the fifth wheel and is charged.

NOTE! DO NOT USE THE BREAKAWAY SWITCH AS A PARKING BRAKE, AS IT IS INTENDED FOR EMERGENCY USE ONLY AND SUCH USE WILL DRAIN YOUR RV BATTERY.

RIDE HEIGHT OF FIFTH WHEEL- CLEARANCE

When the fifth wheel is connected to the tow vehicle, check the ground clearance and front to rear pitch of the fifth wheel. If the front of the unit is too high, weight will be transferred behind the axles, causing the unit to fishtail and the rear axle tires to prematurely wear. If the front of the unit is too low, additional weight will be transferred to the truck. To achieve proper ride height, adjust the pinbox by removing the bolts on each side and raising or lowering the box until the proper holes are aligned, then reinsert and tighten the bolts. Re-tighten the pinbox bolts after the first 50 miles.



WARNING: MODIFYING THE SUSPENSION OF YOUR FIFTH WHEEL OR TRAVEL TRAILER TO MEET A LEVEL RIDE HEIGHT OF YOUR TOW VEHICLE IS NOT RECOMMENDED AND WILL VOID THE WARRANTY OF YOUR GULF STREAM PRODUCT. SUSPENSION MODIFICATION CAN CAUSE ADVERSE HANDLING, WHICH COULD RESULT IN AN ACCIDENT CAUSING INJURY OR DEATH.

VEHICLE LOADING

CARRYING CAPACITY

During the design and development of our travel trailer and fifth wheels, the number and size of storage compartments and the liquid tank capacities are maximized for value and convenience. However, be mindful that if all holding tanks are filled to capacity, and all storage compartments and cupboards are filled to the maximum volume, the travel trailer or fifth wheel could be overloaded. Refer to the manufacturer's labels posted inside and outside of the unit for unit weight information (See Fig. 1 & Fig. 2).

The amount and placement of cargo will also affect the amount of water and LP gas that you can carry. Water weighs 8.3 pounds per gallon and propane weighs 4.2 pounds per gallon. Periodically reweigh your unit. Different traveling configurations may change your loading and weight pattern.



WARNING! DO NOT EXCEED THE RATED LOAD OF THE RV OR THE RATED LOAD OF ANY AXLE! EMPTY ALL HOLDING TANKS BEFORE FILLING FRESH WATER TANK OTHERWISE YOU WILL LIMIT CARGO CAPACITY. CAMPGROUNDS SUPPLY DUMP STATIONS WHICH CAN BE UTILIZED.

LOADING TIPS

After you have determined how much weight you can safely carry and selected those items to make up that weight, make a list and keep it for future reference. Load the RV and distribute the load so that you get proper weight on the axles and hitch. Do not load upper cabinets with heavy items. Secure and brace items so they won't move during travel, thereby shifting the load in the RV. Do not load heavy items near either end of the RV or on the rear bumper. Adjust cargo storage to keep the side to side wheel loads as equal as possible. Carry only as much water as needed for travel use or to balance the load. Always empty your waste water and sewage holding tanks before traveling.



WARNING! ONLY FACTORY INSTALLED REAR BUMPER ACCESSORY RECEIVERS (OPTIONAL) ARE APPROVED FOR USE ON THIS PRODUCT. DO NOT INSTALL ANY ADDITIONAL TYPE OF WEIGHT CARRYING RACK OR FRAME TO THE REAR BUMPER OR ANY CHASSIS OR BODY COMPONENT OF THE RV. DAMAGE TO THE RV AND UNSTABLE HANDLING CHARACTERISTICS MAY RESULT.



WARNING! TOWING ADDITIONAL TRAILERS BEHIND YOUR FIFTH WHEEL OR TRAVEL TRAILER (TANDEM TOWING) IS STRICTLY PROHIBITED. CHECK WITH YOUR STATE OR ANY STATE YOU PLAN ON TRAVELING THROUGH TO ENSURE STATE LAW IS BEING FOLLOWED. MANY STATES HAVE SPECIFIC LENGTH RESTRICTIONS THAT MAY BE VIOLATED IF "TANDEM TOWING".



WARNING: EXCEEDING THE GAWR, GVWR, OR GCWR OF YOUR RV/TRUCK COMBINATION CAN CAUSE UNDESIRABLE HANDLING CHARACTERISTICS AND MAY CREATE A SAFETY HAZARD. MODIFICATION OF YOUR VEHICLE BY ADDITION OF RACKS NOT SPECIFIED BY THE MANUFACTURER TO CARRY ADDITIONAL EQUIPMENT OR VEHICLES/TRAILERS IS STRICTLY PROHIBITED, MAY CREATE A SAFETY HAZARD, AND MAY VOID YOUR WARRANTY.

Make a loading diagram of your properly loaded RV. It will help you locate where specific items are stored, and will help speed the loading process. Store emergency items in a readily accessible location. Include tools, first-aid kit, rain gear, flashlight, highway warning devices, and an electric cord or light.

The difference between the empty weight and the weight of the RV in traveling configuration is your usable load. If the loaded weight of your RV exceeds the GVWR or the weight on any axle exceeds that axle's GAWR, the RV is overloaded and you'll have to remove items to bring the weight down to or below the GVWR and GAWR.

All items must be considered for their weight and stored according to how heavy they are. Heavy items should be placed close to the floor and in the center of the vehicle. **DON'T FORGET TO INCLUDE THE ITEMS YOU PURCHASE ON YOUR TRIP.**

Luggage and similar cargo carried inside the vehicle must be secured to prevent possible damage in the case of a sudden stop or an accident.

WEIGHING YOUR TRAILER

In order to make sure the trailer is not overloaded you should periodically weigh it in a loaded condition. You will want to check the weight on the axles on travel trailers with the trailer hitched to the vehicle as well as when not hitched if you are using a weight distribution hitch. On fifth wheels you will need the weight of the truck to determine the pin weight of the fifth wheel. Please review the following guidelines for weighing your trailer.

TRAVEL TRAILERS

Pull your fully loaded travel trailer onto the scale and leave it hitched to the vehicle as shown in diagram A. This will give you the actual Gross Axle Weight (GAW) as pulled down the road. Check your Federal ID label (FIG. 1) to see what the maximum rating for your axles is and make sure they are not overloaded. If necessary, redistribute or remove weight within the trailer.

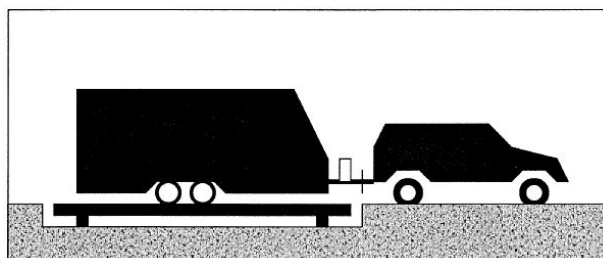

Diagram A

Lower your front jack and unhitch the trailer as shown in diagram B. Record this weight. This weight is necessary to determine the hitch weight.

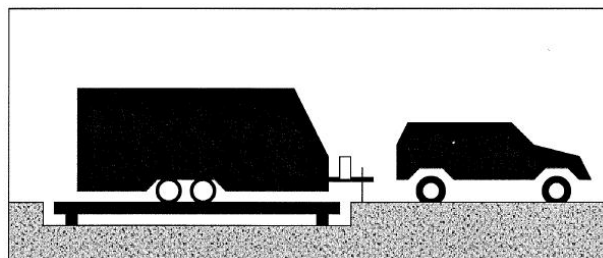

Diagram B

Next, move the trailer so that the front jack and the axles are on the scale as shown in diagram C. This will give you the Gross Vehicle Weight (GVW). This weight must not exceed the trailer's GVWR. If it does you will need to remove some cargo from your trailer.

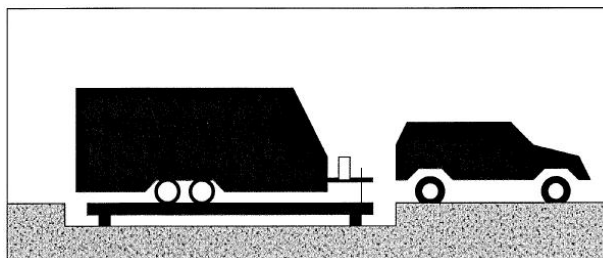

Diagram C

To determine your hitch weight, take the final GVW and subtract the axle weight recorded per diagram B. Most hitch weights should fall between 9-15% of the total trailer weight. You may have to shift some of your cargo to remain within this parameter.

FIFTH WHEELS

Pull your fully loaded fifth wheel onto the scale per Diagram D. This will give you the actual Gross Axle Weight (GAW) as pulled down the road. Check your Federal ID label (FIG. 2) to see what the maximum rating for your axles is and make sure they are not overloaded. If necessary, redistribute or remove weight within the fifth wheel.

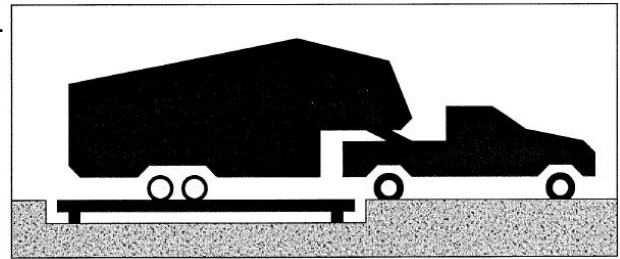

Diagram D

To determine the pin weight of the fifth wheel you must weigh the truck with the fifth wheel hitched as shown in Diagram E. Record this weight. Then disconnect the fifth wheel and weigh the truck again as shown in Diagram F. Subtract the difference between the two weights and you will arrive at your pin/hitch weight. Adjust your cargo accordingly to remain within 23-25% of the GVW of the fifth wheel. The GVW is the GAW added to the pin/hitch weight.

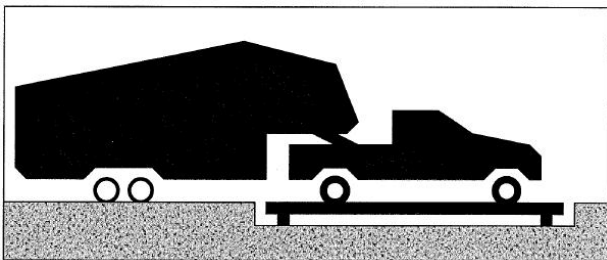

Diagram E

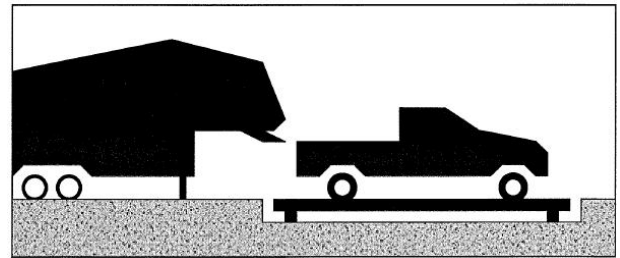

Diagram F

MANUFACTURER'S LABELS

Your vehicle is equipped with several federally required labels pertaining to the vehicle's weight, load capacity and operating limitations.

On the front, left exterior wall is the federal ID label that lists the unit's manufacturer's serial number, the front and rear GROSS AXLE WEIGHT RATING (GAWR), the vehicle's GROSS VEHICLE WEIGHT RATING (GVWR), tire and wheel rim sizes, tire operating pressure, chassis serial number and the VEHICLE IDENTIFICATION NUMBER (VIN). (FIG.2)

MFD BY / FABRIQUE PAR: GULF STREAM COACH, INC.		REFER TO TRIP PLANNER FOR MAXIMUM VEHICLE LOADING			
DATE OF MFG/FABRIQUE DATE - GULF STREAM 10/14/10	INC. VEH. MFD. BY: N/A	DATE OF MFG/FABRIQUE N/A	PINNIT/STAKE 5098kg (11240 LB)		
FRONT AXLE / BARRIÈRE AVANT 2304 kg (5080 LB)	FRONT / AVANT ST225/75R16 D	FRONT / AVANT 15 x 6	PRESS. DE BOMBE À FROID/CHÂLD INFL PRESS 448 kPa (65 psi)		
REAR AXLE / BARRIÈRE ARRIÈRE 2304 kg (5080 LB)	REAR / ARRIÈRE N/A	REAR / ARRIÈRE N/A	PRESS. DE BOMBE À FROID/CHÂLD INFL PRESS 448 kPa (65 psi)		
THIS VEHICLE HAS BEEN COMPLETED IN ACCORDANCE WITH THE PRIOR MANUFACTURERS' TOW WHERE APPLICABLE. Dec-10					
THIS VEHICLE CONFORMS TO ALL APPLICABLE FEDERAL MOTOR VEHICLE SAFETY STANDARDS IN EFFECT IN EFFECT ON THE DATE OF MANUFACTURE. - CE VÉHICULE EST CONFORME À TOUTES LES NORMES QUI LUI SONT APPLICABLES EN VERTU DU RÈGLEMENT SUR LA SÉCURITÉ DES VÉHICULES AUTOMOBILES DU CANADA EN VIGUEUR À LA DATE DE SA FABRICATION					
V.I.N. / N.A.V.	1NL1G1TN23B1105179	Serial No. / No de serie	51-1-T-1295SBW-105179		
B/C					

(FIG. 2) FEDERAL ID LABEL

TRAILER WEIGHT INFORMATION						
CONSULT OWNER MANUAL(S) FOR SPECIFIC WEIGHING INSTRUCTIONS AND TOWING GUIDELINES.						
MODEL	30 TRET			kilograms pounds		
SERIAL #	72035			GVWR*	4975 10970	
				UVW*	3386 7466	
				NCC*	1589 3504	
CARGO CARRYING CAPACITY (CCC) INFORMATION						
Your carrying capacity is affected by everything put into your trailer. Use this chart to support your travel needs.						
		Added weight		Adjusted CCC*		
		gallons	kilograms	pounds	kilograms	pounds
Fresh water @ 8.3 lb/gal	water tank & heater	66	248	548	1341	2956
LP-Gas @ 4.2 lb/gal	LP tank	14	27	60	1313	2896 = CCC*
* Weights shown are calculated weights with options included. Dealer installed equipment will reduce CCC.						
GVWR (Gross Vehicle Weight Rating) is the maximum permissible weight of this trailer when fully loaded. It includes all weight at the trailer axle(s) and tongue or pin.						
UVW (Unloaded Vehicle Weight) is the weight of this trailer as manufactured at the factory. It includes all weight at the trailer axle(s) and tongue or pin. If applicable, it also includes full generator fluids, including fuel, engine oil and coolants.						
NCC (Net Carrying Capacity) is equal to the GVWR minus the UVW.						
CCC (Cargo Carrying Capacity) is equal to the GVWR minus each of the following: UVW, full fresh (potable) water weight (including water heater), and full LP-Gas weight.						

(FIG. 3) WEIGHT INFORMATION LABEL

VEHICLE WEIGHT INFORMATION LABEL

All GULF STREAM vehicles have a weight information label posted inside the kitchen cupboard or attached to the back cover of the owner's manual (FIG. 3). Please refer to this label to see the shipping weight of your vehicle and the net carrying capacity of your water and LP tanks.

The vehicle weight information label also contains the net cargo capacity. This is the maximum weight designated by GULF STREAM that can be utilized for cargo. Any addition of accessories by you or the dealer reduces this amount proportionally with the weight of added accessories.

FEDERAL WEIGHT DEFINITIONS

GAWR: The allowable weight, INCLUDING CARGO, which can be SAFELY supported by a specified axle.

GVWR: The maximum permissible weight of your vehicle, INCLUDING CARGO, ALL OPTIONS AND WATER.

Dangers of Overloading

One of the attractive selling points of the GULF STREAM is the abundance of storage, both inside and outside the vehicle. However, there are limits to what the vehicle can carry as has been shown above. When preparing for a trip and while on your travels, always be mindful of WHAT YOU ARE STORING, HOW MUCH IS WEIGHS AND WHERE YOU ARE STORING IT. BEWARE OF OVERLOADING. In addition to causing premature wear, overloading can cause problems in the area of handling characteristics. An overloaded vehicle will take longer (time and distance) to stop in an emergency. Overloading can also cause added wear to components such as tires and wheel bearings. Overloading can also cause overheating of the tow vehicle in some instances.

The solution? Stay on top of your vehicle weight situation at all times. Know where you stand when it comes to the GVWR, GAWR and GCWR.

TIRES

The tires installed on your vehicle have been pre-selected as the proper size and weight by the chassis manufacturer for the type and weight of the travel trailer built. The Tire and Loading Information label (Fig. 4) located on the side of the trailer will show the proper tire size for your coach and the recommended air pressures. When replacing tires, make sure that those guidelines are followed.

TIRE MARKINGS

Sample tire size: ST205/75R15 C

- ST reflects the "Trailer" usage. Trailer tires should be used on trailers and never on passenger cars or trucks.
- 205 indicates the "contact patch" width. The contact patch is the amount of tire surface that actually comes into contact with the pavement. In this sample case, the width is 205 millimeters wide.
- 75 indicates the height to width ratio of the tire.
- R identifies the construction type of the tire. R – Radial, B – Bias belted, D – Diagonal Bias.
- 15 is the rim size (measured in inches).
- C is the load range.

TIRE AND LOADING INFORMATION RENSEIGNEMENTS SUR LES PNEUS ET LE CHARGEMENT			
The weight of cargo should never exceed		kg or	lbs.
Le poids du chargement ne doit jamais dépasser		749kg or	1652 lb.
TIRE PNEU	SIZE DIMENSIONS	COLD TIRE PRESSURE PRESSION DES PNEUS A FROID	SEE OWNER'S MANUAL FOR ADDITIONAL INFORMATION VOIR LE MANUEL DE L'USAGER POUR PLUS DE RENSEIGNEMENTS
FRONT AVANT	ST205/75R15 C	345 kPa (50 psi)	SN: 51-1-T-124RKL-105154 FD-335
REAR ARRIERE	ST205/75R15 C	345 kPa (50 psi)	
SPARE DE SECOURS	ST205/75R15 C	345 kPa (50 psi)	

(FIG. 4) TIRE LOADING AND INFLATION

TIRE LOAD RATINGS

Load ratings for tires go up as the corresponding letter changes. For example, load range “E” tires have a heavier rating than load range “D” tires. Load capabilities of tires change as the psi (air pressure) is lowered. As much as 220 lbs. of load carrying capacity is lost per tire for each 5 psi below the recommended inflation. This decreased load amount varies from one tire manufacturer to the next, therefore it is recommended that you contact your tire manufacturer for further information in this regard.

TIRE AIR PRESSURE



WARNING: PROPER TIRE AIR PRESSURE IS CRITICAL FOR SAFE OPERATION OF THIS VEHICLE! IT IS REQUIRED THAT THE TIRE AIR PRESSURE IS CHECKED PRIOR TO EACH USE OF THIS VEHICLE.

When checking air pressures, if the tire has been driven more than 6 miles, you can add 4 to 6 psi to the rated maximum “cold” inflation recommendations. For example, if the tire has a maximum rating of 90 psi cold, you can inflate the tire to 96 psi after being driven on. Under inflation generates excessive heat (a tire’s worst enemy!), increases tread wear in the shoulder area, and reduces your vehicle’s fuel economy.

Never mix radial, bias belted or bias type tires. Never mix brands. This can adversely affect vehicle handling and stability. Use only the tire size that is listed on the Safety Compliance Certification Label. If you have a question about the label, please call Gulf Stream.

TIRE MAINTENANCE

When cleaning tires, try to use a tire-cleaning agent. Never use any cleaner that contains solvents. Solvents will draw oil from tires and cause them to prematurely crack. Inspect your tires prior to each trip, looking for bulges or cracks in the sidewalls.

When storing your recreational vehicle for long periods of time, you should completely unload the vehicle so that a minimum weight will be placed on the tires. Make sure the tires are inflated to the recommended operating inflation pressure. Avoid moving the vehicle during extremely cold weather. Move the vehicle at least every three months to prevent ozone cracking in the tire bulge area as well as “flat spotting” from prolonged strain of sidewall and tread deflection. Make sure you check the inflation and adjust to the recommended operating pressure before putting the vehicle back into service.

Tire life expectancy varies. Some tires reach their life expectancy and may need to be replaced in as little as six years regardless of tread wear. Please refer to the tire manufacturer for recommendations in regard to tire life expectancy.

WHEEL NUT TORQUE

Wheel nut torque is a very important safety measure that should be checked often. Travel trailer tires may carry higher loads than typical passenger car tires. Further, travel trailer tires on tandem axle trailers are subject to high side-to-side load stress when making slow or tight turns. These circumstances require extra maintenance on the wheel bearings and brakes, and also extra care when checking your wheel lug nut torque.

To properly check your wheel lug nut torque you will need a torque wrench.



WARNING! ON YOUR INITIAL TRIP, CHECK THE LUG NUT TORQUE AT 50, 100, AND 150 MILES. ALWAYS CHECK MORE OFTEN IF YOU HAVE OPTIONAL ALUMINUM WHEELS.



WARNING! BEFORE EACH TRIP AND EACH TIME A WHEEL IS REMOVED BE SURE TO TIGHTEN YOUR WHEEL LUG NUTS AS PER THE FOLLOWING GUIDELINES:

“Lite” Towables: 50 – 75 ft. lbs.

All other Towables: 85 – 95 ft. lbs.



WARNING! DO NOT OVER TIGHTEN THE LUG NUTS! OVER TIGHTENING MAY CAUSE THE LUG STUDS TO SHEER OFF UNDER CERTAIN DRIVING CONDITIONS.

ELECTRIC BRAKE SYSTEM

The electric brakes on your travel trailer or fifth wheel are similar to those on your automobile; the difference being that they are activated by 12 volt electrical impulse as opposed to a hydraulic system. The impulse comes from a brake controller, which in affect regulates the flow of electrical current to the trailer brakes.

Brakes are usually maintenance free; however, road and driving conditions may at times cause them to grab, drag, or fade. Also, improper grounding of the trailer to the tow vehicle, irregular current, or a short circuit in the wiring system will cause electric brakes to malfunction. In any case, we recommend that you consult your dealer or local trailer brake specialist on these problems.

Electric brakes should be checked periodically to determine the condition of the magnets and drums, and whether wiring connections are still secure (see manufacturer’s instructions). Brakes can be adjusted to activate ahead of the tow vehicle brakes for best road control. Consult the manufacturer’s instructions or your dealer for detailed maintenance and service procedures.

TRAVEL TRAILER “HOUSE” SYSTEMS

SAFETY

Your new vehicle has been provided with numerous safety features. Please review all features and familiarize yourself with their proper operation prior to using this recreational vehicle.

EMERGENCY WINDOW EXIT: All Gulf Stream vehicles are equipped with two exit paths from any sleeping area. One exit path is the entry door and the second exit path can be an emergency exit window or roof hatch. Inspect your recreational vehicle to find each emergency exit window or roof hatch. They will be identified by a red decal that reads “EXIT” and will have a red handle on the window. Some emergency exit windows slide open to the side and some pop open from the bottom with a hinged top. Test your emergency exit windows for proper operation before each trip.

FIRE EXTINGUISHER: This is required equipment with all new Gulf Stream recreational vehicles and is usually located just inside side entry door. It is activated by pulling the ring-pin and squeezing the handle. Direct contents at the base of the fire. Read instructions on bottle. Check regularly to insure that charge is adequate.

SMOKE DETECTOR: Located in kitchen/dining area or between kitchen/dining area and sleeping areas. Sounds alarm if it detects smoke. Test regularly and replace battery at least twice a year. Consult smoke detector manual.

LP GAS DETECTOR: Located in kitchen/dining area near floor. Sounds alarm if it detects LP gas. Test regularly. Consult LP gas detector owner’s manual. False alarms or “beeping” can be an indication of a low “coach” or “house”

battery. Remember, LP gas is heavier than air and will float at floor level. DO NOT block your LP gas detector by leaving items lying in front of it on the floor.

CARBON MONOXIDE (CO) DETECTOR: Located in rear hall or sleeping area. Sounds alarm if it detects Carbon Monoxide at a dangerous level. Test regularly. Consult CO detector manual. Replace batteries at least twice a year. This equipment is available only on models that have generator preparation.

ELECTRICAL

Your GULF STREAM is equipped with two (2) separate electrical systems that provide your vehicle with power on the road and in camp. A chassis 12 volt DC system and a 110 volt AC system are installed.

12 VOLT DC SERVICE

The house 12-volt system is used for running most interior lights and appliances. Even though your refrigerator has an option to run on 110-volts AC, the refrigerator circuit board uses 12 volt DC for it's operation. Also, the roof mounted air conditioner(s) are powered by 110-volts AC, but also need 12 volts DC to power the thermostats. The 12 volt DC power is provided by one or more "house" batteries. The house batteries are charged by a convertor/charger when the recreational vehicle is plugged into shore power or when the generator is running. Other items in the coach that run on 12 volt DC power include: water pump, water heater, furnace, slide out systems, powered vents, etc.

Like your home, the vehicle has a 110-volt alternating current (AC) system that requires an external source of 110-volt electricity. A shoreline connection (extension cord) or an optional electrical on-board power generator or an inverter can provide this power. In order to use your 110-volt electrical system, your shoreline (power cord) should be plugged into either a properly rated external power source or the generator should be running, or in some cases the inverter should be turned on. TO CONSERVE BATTERY POWER, USE OF THE SHORELINE IS RECOMMENDED WHENEVER POSSIBLE. (FIG. 5)

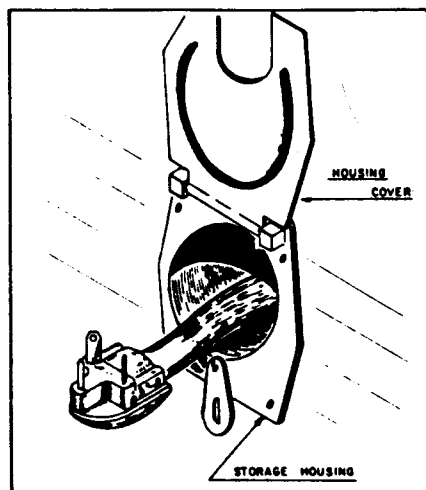

(FIG. 5) 110-V SHORELINE CONNECTION (30 AMP SHOWN)



SHORELINE GROUND WARNING: IF YOUR POWER SUPPLY IS NOT PROPERLY GROUNDED, YOU MAY EXPERIENCE A DANGEROUS SHOCK WHEN STANDING ON THE GROUND AND TOUCHING A METAL PORTION OF THE RV. USE A CONTINUITY TESTER TO ENSURE PROPER GROUNDING.



EXTENSION CORD WARNING: DO NOT USE AN EXTENSION CORD WITH A CURRENT RATING LESS THAN THE AMPERAGE YOUR RV REQUIRES. EXTRA EXTENSION CORDS REDUCE THE AMPERAGE AND VOLTAGE BEING SUPPLIED TO THE RV AND MAY CAUSE DAMAGE TO ELECTRICAL COMPONENTS!

30-AMP AND 50-AMP 110-VOLT AC SERVICE

Your recreational vehicle is provided with either 30 amp or 50 amp electrical service, depending on the size of the RV and the electrical options installed. You can identify the type of service by reviewing the end of your shoreline connection and comparing it with FIG. 6 on the next page.

30-amp service is 110-volt service limited to a total of 30 amps of draw. A large three pronged power supply cord identifies this type of power supply (FIG. 5). Each appliance in your vehicle is capable of working by itself with this type of service. However, you may not be able to operate all your appliances at the same time without causing a circuit breaker to blow.

A typical component in your vehicle such as a TV or VCR will draw only about 1 amp. Other items such as coffee makers and microwaves will draw 10-15 amps when used. Roof air conditioners usually draw the most, pulling up to 15 amps when the compressor is running. So as you can see, with 30 amp service, you can use only one air conditioner when hooked up to shore power even if your coach is equipped with two. The combined draw of two air conditioners may only be 29 amps, but other items in your coach such as converters, refrigerators, water heaters, etc. will put your draw over the 30-amp mark causing a circuit break. You may be asking yourself "Why then did Gulf Stream install two a/c's if I can only use only one at a time?" This is done so that you can direct more cold air to the front or rear of the vehicle if you desire. Plus, usually they both can be operated while using your generator.

30-amp service is the most common electrical service in the RV industry and can be found at most, if not all, RV campgrounds. This makes 30-amp service the most user friendly as far as availability. If your vehicle is equipped with 50-amp service, you will be able to run any installed appliance at any time when a 50-amp service park is available or you are running your generator.

50-amp service is also 110-volt service, but it is capable of running up to 50-amps of draw. Some people believe that 50-amp service is the same as having 220-volts of ac power. Yes, 50-amps of service does have 220-volts, but only 110-volts is capable of being supplied to any part of your system at any given time. A four pronged power cord that is very unique identifies 50-amp service, as two of the four prongs each carry 110-volts of ac power. 30-amp service has only one prong that carries 110 volts of ac power. Each of the 110-volt lines in a 50-amp cord supplies power to a designated part of your RV. In doing this, when ac powered components are installed they can be put on separate power feeds according to how much amperage they draw. One example of this method consists of installing two air conditioners for use at the same time. Each one is powered by a different power supply feed; therefore they both can be used simultaneously. Think of 50-amp service as having two shoreline power cords in one casing as opposed to only one in 30-amp service.

If you travel to an RV park that does not offer 50-amp service you will have to use an adapter to hook up to shore power. Use of an adapter is not recommended, but may not be avoidable. When using an adapter, remember that your coach will not have sufficient power to run as many options as with 50-amp service. You may be able to run both your air conditioners for a limited time; however, this will cause damage to both your ac units as well as other components by operating them on insufficient power.

Listed below are components that might be used in Gulf Stream vehicles and the maximum amperage draw each one has. Whether your power supply is 30-amps or 50-amps this chart may help you decide which components you can safely use for an extended period without damage.

Components	Amperage
Roof air conditioners (each)	15
Electric water heater	12
Microwaves	15
Hair dryer	2
Washer/dryer	10
Vacuum	5
TV	1.0
VCR	1.0
Engine block heater	10
Heart Inverter/Charger	22
Magnetek charger	14
Refrigerators	3.5
Space heaters	10-15
110-volt lamp	1.0

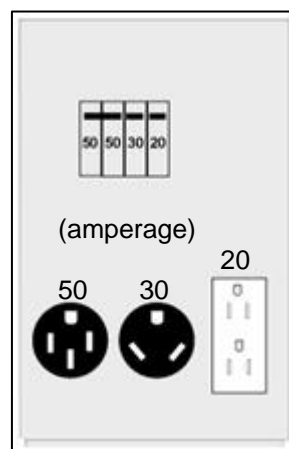

(FIG. 6) 20/30/50 AMP HOOKUP (TYPICAL)

POWER CONVERTER

Your vehicle is equipped with an electrical power converter that changes 110-volt power to 12-volt power to run 12-volt powered appliances in your vehicle. It gets the 110-volt power by way of the shoreline or the optional generator. The power converter will be located either under the side of the rear bed, under the refrigerator or at the base of a cabinet (FIG. 7A).

The circuits in the vehicle are protected by circuit breakers and fuses. Locate the converter and see where the fuses are located. If you blow a fuse, turn off the appliance. Unplug the fuse. Check the fuse for breakage (FIG. 7B) and

replace it with a new fuse of the proper rating. If the fuse continues to fail, contact your nearest dealer. NEVER REPLACE A FUSE WITH A HIGHER RATED FUSE THAN WHAT IS DESIGNATED!

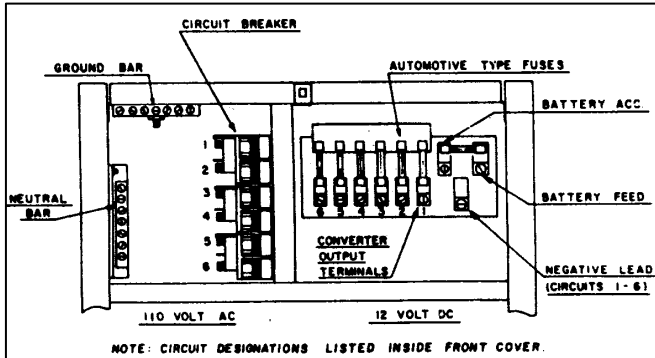

(FIG. 7A) 45 AMP CONVERTER PANEL (TYPICAL)

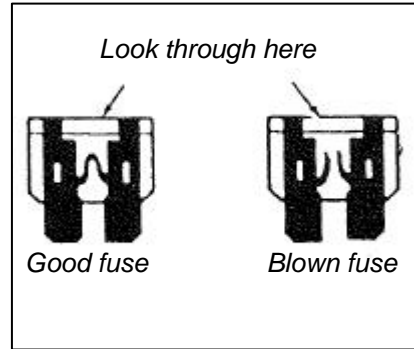

(FIG. 7B) TYPICAL FUSE

GROUND FAULT INTERRUPTER

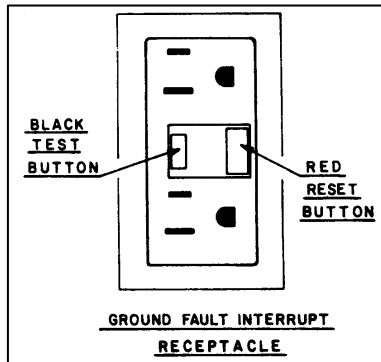

(FIG. 8) GFI RECEPTACLE

Your unit is equipped with a Ground Fault Interrupter that will stop the current in the event of a short. If you find that 110v AC power is missing at any receptacle of the motor home, first check to see if the GFI button has been tripped (FIG 8). Then check the breaker panel (FIG. 7A). If the GFI button has been tripped, you may have a short in your circuit. Please have a professional test and repair as needed. The GFI recepts are located near the kitchen sink, the bath sink and/or the exterior receptacle location.

BATTERY

The RV has one or more DEEP CYCLE 12V batteries on board (as equipped by dealer or consumer). Both are maintained in the same manner. Check the electrolyte fluid levels on a regular basis, especially during hot weather conditions. Refill as necessary with either distilled water or clean tap water in an emergency. DO NOT ALLOW THE FLUID LEVELS IN THE BATTERIES TO FALL BELOW THE INTERNAL BATTERY PLATES. DAMAGE TO THE BATTERIES MAY RESULT AND SHORTEN THE LIFE OF THE BATTERIES.

When charging the batteries, do not charge at such a fast rate as to cause spewing of the electrolyte from the cells. However, do charge the battery with the cell vent caps off.



WARNING: NEVER USE AN OPEN FLAME AROUND BATTERIES. AVOID MAKING ELECTRICAL SPARKS. FUMES FROM THE BATTERY ARE COMBUSTABLE. KEEP AN EYE OUT FOR CORROSION ON THE BATTERY TERMINALS. CORRODED TERMINALS CAN CAUSE A LOSS OF AVAILABLE POWER AS WELL AS CUT DOWN ON THE EFFICIENCY OF THE CHARGING/ELECTRICAL SYSTEM. THIS COULD LEAD TO A SITUATION WHERE THE BATTERY ISN'T CHARGED ENOUGH TO START THE VEHICLE. ALWAYS WEAR EYE PROTECTION AND GLOVES WHEN WORKING WITH BATTERIES.

If your batteries have problems prior to the end of their warranty period, consult the nearest representative of the battery manufacturer.

When it is time to replace the batteries, be sure to replace them with quality batteries of equal electrical and physical properties. Contact your nearest dealer for advice in the selection of new batteries.

BATTERY TYPES AND CHARGING

Only similar batteries should be connected together in one bank. Do not connect old and new batteries, or wet and gel cell batteries together. Deep-cycle batteries are usually rated in Amp-hours, which is based on a 20-hour discharge rate. Therefore, a 100 amp-hour battery can deliver 5 amps for 20 hours. Deep-cycle batteries can be discharged about 80% of capacity before damage occurs. Shallow cycling (50%-60% drain before recharge) will result in much longer battery life. To find out how long your batteries will last when using various equipment in your coach, research the amperage of the items in use, and use that number to gauge what size amp-hour battery you think you need. Keep in mind that you should recharge your batteries when they are 50% discharged, so only half of the amp-hour rating is actually used.

Completely charging wet cell deep-cycle batteries requires the battery voltage to be raised beyond what is known as the gassing point. This is the voltage at which the battery begins to bubble and gas is given off. If charging stops short of this point, sulfate is left on the plates and deterioration of the battery begins. The gassing point will vary with battery temperature. At 77 degrees F, the gassing point of a 12-volt battery is about 14.0 volts.

MONITOR PANEL

Your vehicle has an electrical panel that can provide you with important information about various systems on the RV including the condition of your batteries.

The panel is most often located above the stove or on the wall near the stove. The monitor panel will give you information including:

- How much potable (fresh) water remains.
- How full your black (sewage) tank is.
- How full your gray (waste water) tank is.
- How much LP gas is in your LP tank.
- How much charge your battery has.

The monitor panel can give a false reading on the waste tank (black and gray) levels if those tanks have not been properly flushed or recently cleaned.

TV ANTENNA AND CABLE CONNECTIONS

The TV signal in your RV is controlled by a powered antenna switch. When the switch is turned on, you will have antenna reception throughout the RV. When the switch is off, you will have cable reception. The diagrams below show a typical switch and wiring setup for your RV.

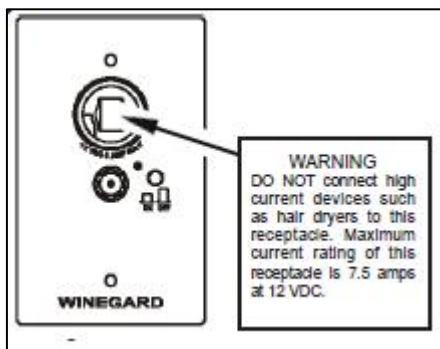

(FIG. 9) ANTENNA POWER/WALL PLATE

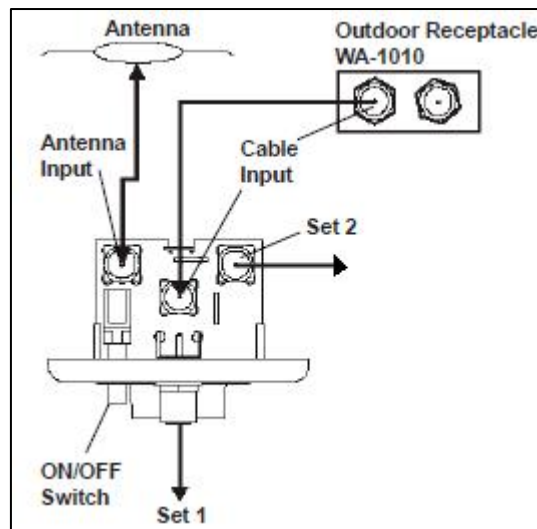

(FIG. 10) ANTENNA HOOKUP (TYPICAL)

RAISING AND LOWERING YOUR ANTENNA

RAISING:

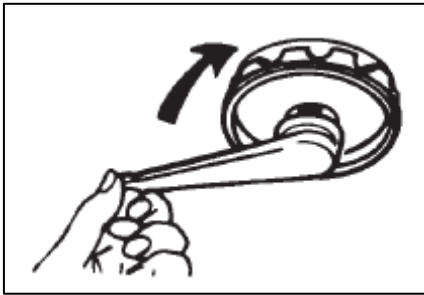

Crank clockwise until some resistance is felt on handle.

ROTATING:



Pull down with both hands and rotate plate for better signal.

LOWERING:

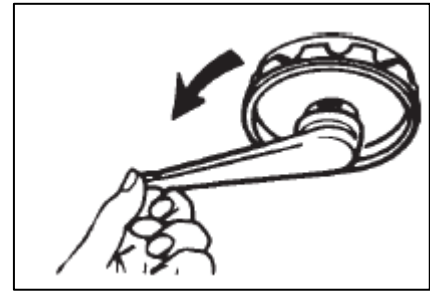

Rotate plate until arrows align. Crank counter-clockwise until down.

If you have bad or no reception, perform the following checks:

- Check with neighbors to see how good local cable and antenna reception has been.
- Turn the antenna power/booster on.
- Set your TV to receive "Air" or "Cable", whichever signal you are watching.
- Check all cable ends to make sure that no ground strands are touching the center cable wire.

LP GAS

GENERAL

The liquid Petroleum gas system in your unit furnishes fuel for various appliances. It is comprised of propane (LP) gas. LP gas provides an efficient and inexpensive source of energy.

The gas is stored in a pressure tank located on or under the chassis of your unit. Under pressure, the LP gas turns to vapor; it is this vapor that burns.

Each tank has an automatic eighty percent stop-fill valve that allows space in the tank for vapor expansion. The high pressure of the vapor in the tank is reduced in two stages as it makes its way to your appliance. The tank pressure will vary with temperature and altitude, but it may be in the range of 100 to 250 pounds per square inch (psi) or more. It is reduced by a pressure regulator to about 12 psi in the first stage and then to about 6.25 ounces in the second stage. The 6.25 ounces psi can also be expressed as 11 inches of water column.

The LP gas system is designed and built to rigid standards and tested before leaving the factory. Your dealer also tests the system prior to customer delivery.

NOTE: YOUR DEALER IS RESPONSIBLE FOR A THOROUGH LP GAS SYSTEM CHECK PRIOR TO DELIVERY. DO NOT ACCEPT THE UNIT UNTIL THIS CHECK HAS BEEN COMPLETED.

Except for simple maintenance and occasionally tightening a connection, you should take your unit to an authorized dealer for LP gas problems. The LP gas tank should always be filled by an authorized LP supplier.

NOTE: YOUR UNIT'S MANUFACTURER IS NOT RESPONSIBLE FOR PERSONAL INJURY OR PROPERTY DAMAGE RESULTING FROM IMPROPERLY MAINTAINED LP GAS APPLIANCES AND SYSTEMS.

CAUTIONS: READ LP GAS PRECAUTIONS IN THE FRONT OF THIS MANUAL. BECOME FAMILIAR WITH THEM AND MAKE SURE YOUR ENTIRE FAMILY IS COMPLETELY AWARE OF THE SAFETY ASPECTS OF LIVING AROUND LP GAS.

CLIMATE DIFFERENCES

The appliances in your vehicle will not function if the LP gas does not vaporize. Propane will continue to vaporize down to -44 degrees F.

Propane has become the main type of LP gas used in RVs in recent years. **Butane should never be used.** The LP gas dealer will have the correct type or blend for his locale. If you plan on traveling from a warm climate to a cold climate, check with your local gas dealer to see if the blend he supplies is appropriate for the part of the county you plan on visiting.

OPERATION

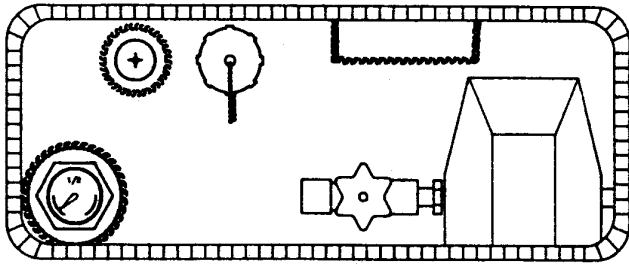

(FIG 11). LP GAS TANK

To operate any LP gas appliance, the LP gas tank's service valve must be OPEN (FIG 11). When first used, or after a refill, there may be some air in the gas lines that will escape when the range burner or similar gas valve is opened. The air may extinguish the match or igniter the first time or two you attempt to light a stove burner. Also remember that when you close the tank's service valve, some gas will remain in the lines. To completely bleed the lines of gas, close the tank valve and light the range burner. When the flame burns out, turn off the appliance.

FILLING THE LP TANK

Make sure that all burners and pilot lights are turned OFF prior to having a gas supplier refill your LP tank.

Drive your unit to the LP supplier for filling. Never remove the tank from the unit. The supplier will connect his fill nozzle to your unit's LP tank FILL VALVE.

When the tank is being filled, the service valve must be CLOSED. The 20 percent LIQUID LEVEL GAUGE must be OPEN.

The 80 percent STOP FILL VALVE may close the valve before liquid appears at the 20 percent liquid level gauge, but if liquid does appear, stop filling immediately...the tank is filled to its LP capacity.

Do not use a wrench to tighten the service valve or the 20 percent gauge. They are both designed to be closed leak-tight by hand. If you cannot hand-tighten the valve, the valve may need repair or replacement. Consult your gas dealer.

YOUR LP TANK MUST BE KEPT FREE OF RUST AT ALL TIMES. IF RUST DOES DEVELOP, THE TANK SHOULD BE CLEANED COMPLETELY FREE OF THE RUST, PRIMED, AND PAINTED WHITE (OR SOME OTHER HIGHLY REFLECTIVE COLOR) WHICH WILL HELP TO REDUCE EXPANSION OF THE LP GAS BECAUSE OF HEAT.

GAS LINE CHECK

Check the gas line connection and all other connections regularly. To check, turn OFF all burners and pilot lights. Open all doors and windows. OPEN the LP gas tank service valve and use soapy water or an approved leak detector fluid to test all line connections. Do not use products that contain AMMONIA or CHLORINE. The appearance of bubbles in the soapy solution indicates a leak. Tighten the connections with two (2) open-end wrenches until the bubbles stop. If this does not take care of the leak, contact your gas dealer. DO NOT OVERTIGHTEN. (FIG. 12)

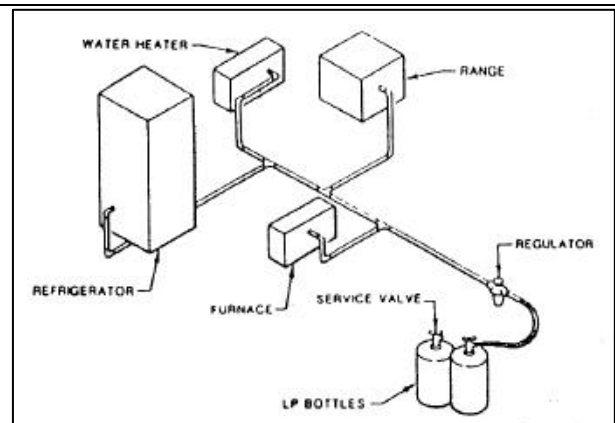

(FIG. 12) LP GAS SYSTEM (TYPICAL)

REGULATOR PRESSURE

Have the gas regulator checked at the beginning of each season and whenever a problem occurs. Proper line pressure is 11 inches of water column. Your RV dealer or gas supplier can perform this needed check.

GAS TANK AND REGULATOR FREEZE-UP

LP gas regulator freeze-up can be prevented if owners are aware of its causes. Freeze-up may be caused by one of these things: moisture in the tank, an overfilled tank or a greater vapor withdrawal demand than the tank can deliver at a particular temperature.

Freeze-up occurs more frequently in cold weather since liquid gas does not vaporize as quickly. This, along with a higher demand, can cause frosting of the tank and regulator. Be sure to have your LP gas supplier add ANHYDROUS METHANOL before filling the tank in cold weather.

Moisture may enter the tank in the LP gas through condensation if air is allowed to enter the tank through an open valve. This can be avoided by using moisture-free gas and keeping all tank valves CLOSED during storage. If moisture is present, have the tank purged by an authorized dealer and have him add the proper amount of ANHYDROUS METHANOL for your tank.

An overfilled tank can allow liquid gas, rather than the needed vapor, to flow through the regulator. This can result in erratic regulator delivery pressure, improper appliance operation and possible frosting of the regulator and gas line. This can be avoided by following the procedures outlined in "Filling the LP Tank." Always contact your local gas supplier for current procedures.

HOSE REPLACEMENT

The flexible LP gas hoses connected to your LP tank should be checked regularly for signs of deterioration and may need to be replaced every two to three years. Be sure to replace the hoses with approved and properly rated products.

REGULATOR VENT MAINTENANCE

Since the LP gas regulator is equipped with a vent that allows the system to "breathe," you must check it on a routine basis to see that it does not become clogged. If dirt, sealant or corrosion clogs the vent, clean it with a toothbrush or similar device. At least once a year have your LP serviceman check the regulator for adjustment and operation.

PLUMBING

FRESH WATER

Fresh water for your RV is provided by filling the FRESH WATER TANK or by hooking directly to a city water connection. These sources supply water to the kitchen sink, shower, lavatory, toilet and water heater. (FIG. 13)

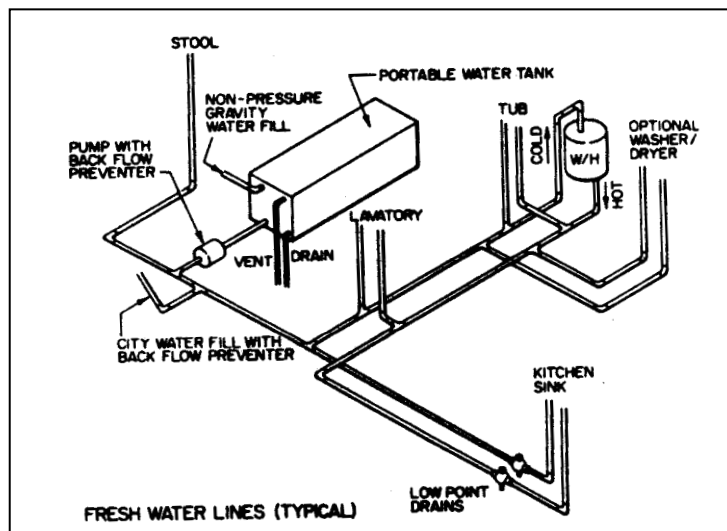

(FIG. 13) FRESH WATER LINES (TYPICAL)

CITY WATER

Open the CITY WATER INLET DOOR and connect a hose to a city pressurized water faucet and to the vehicle's CITY WATER INLET. Some models have a separate water fill for the FRESH WATER TANK. Others have a selector switch to select either LOCAL SUPPLY or FRESH WATER TANK. To use CITY WATER make sure the selector is set to LOCAL SUPPLY. The fresh water tank and water pump are by-passed when the city water hook-up is used.

CAUTION: A PRESSURE REGULATOR SHOULD ALWAYS BE USED WHEN CONNECTING TO CITY WATER. EXCESSIVE WATER PRESSURE CAN DAMAGE LINES AND CONNECTIONS, CAUSING WATER DAMAGE TO YOUR RV. MAKE SURE WATER PRESSURE NEVER EXCEEDS 60 PSI.

WATER TANK

UNLOCK the GRAVITY WATER FILL HATCH and use a hose or vessel to fill the water tank. Or, select FRESH WATER TANK after hooking the hose to the CITY WATER. Watch your monitor panel inside to determine when the tank is full.



WARNING: NEVER LEAVE YOUR COACH UNATTENDED WHEN FILLING THE FRESH WATER TANK! ALTHOUGH PROPER VENTING IS ALLOWED FOR OVERFLOW, THE WATER PRESSURE CAN EXPAND THE TANK AND CAUSE STRUCTURAL DAMAGE AND A POSSIBLE EXPLOSION RESULTING IN DEATH OR INJURY!

Use only fresh, potable water in the storage tank. To insure that the tank is clean, drain after each trip. Sanitize the tank when new, whenever contamination is suspected, or whenever it has not been used for a long period of time.

WATER SYSTEMS CONVENIENCE CENTER

Some models are equipped with a Water Systems Convenience Center located on the exterior road side of the trailer. This area allows for supplying local city water, filling the water holding tank and draining the sewage holding tanks in one, convenient location.

The Water Systems Convenience Center may contain:

- City water hookup
- Selector switch for filling water tank, normal usage or winterizing the water lines.
- Black holding tank flush hookup (optional)
- Release valves for waste water and sewage holding tanks
- Water heater bypass valve for winterizing (optional)
- Fresh water filtration system (optional)
- Hot and cold water line low point drains
- Rally kit (exterior shower)

SANITIZING THE WATER TANK

As approved by the U.S. Public Health Service

To assure complete disinfection of your potable water system, it is recommended that the following procedures be followed on a new system, one that has not been used for a period of time, or one that may have become contaminated. This procedure is also recommended before long periods of storage such as over the winter.

1. Prepare a chlorine solution using 1 gallon of water and ¼ cup of household bleach (sodium hypochlorite solution). With tank empty, pour chlorine solution into the tank. use 1 gallon solution for each 15 gallons of tank capacity. This procedure will result in a residual chlorine concentration of 50 PPM in the water system. If a 100 PPM concentration is required as discussed in item 3, use ½ cup of household bleach with 1 gallon of water to prepare the chlorine solution. One gallon of the solution should be used for each 15 gallons of tank capacity.
2. Complete filling of tank with potable water. Open each faucet and run the water until a distinct odor of chlorine can be detected in the water discharged. Do not forget the hot water taps.
3. Allow the system to stand for at least 4 hours when disinfecting with 50 PPM residual chlorine. If a shorter time period is desired, then a 100 PPM chlorine concentration should be permitted to stand in the system for at least 1 hours.
4. Drain and flush with potable water.

WATER PUMP

The RV water pump is a 12-volt DC appliance that is activated by a switch in the kitchen area or on the monitor panel. The switch may be left ON while camping. This is called a demand system. (FIG. 14)

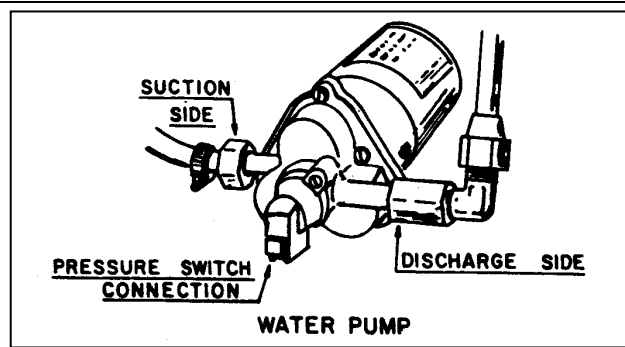

(FIG. 14) WATER PUMP

Turn the faucet on when you want water. The pump will run only as long as needed. If the pump fails when the switch is ON, check the fuse located in the converter. If the pump continues to operate whether the faucet is open or closed, check the water tank to see if it is empty and check to see if there is a leak in the system.

DO NOT RUN THE WATER PUMP WITHOUT WATER IN THE SYSTEM. ALWAYS KEEP THE PUMP SWITCH OFF WHEN THE SYSTEM IS EMPTY OR WHEN CONNECTED TO CITY WATER. RUNNING THE PUMP DRY CAN DAMAGE IT AND VOID THE WARRANTY.

SECONDARY WATER PUMP SWITCH (OPTIONAL)

Some vehicle models have a second water pump switch located in the bathroom near the lav sink. This switch will turn on the water pump whether the main water pump switch is on or off.

WINTERIZING THE WATER PUMP

With the water drained from the potable water tank, disconnect the water pump outlet hose and then turn the pump on to allow the remaining water to be pumped out (less than one cup).

If you desire, you can blow out the water lines with compressed air by opening all valves and placing the air nozzle into the system where the outlet hose has disconnected. Replace pump hose.

DRAINAGE AND SEWER

Your RV has a Drainage/Sewer system that operates much the same way as the one in your home. How extensive the system depends on your unit model and the options you obtained. It includes a drain line from the kitchen sink and shower to a GRAY WATER HOLDING TANK (may vary). There is also a marine toilet and lavatory that empties into a

separate BLACK WATER HOLDING TANK. Some models may have a second GRAY WATER HOLDING TANK to accommodate various floorplans and features. Which tank each sink drains into may vary from one model to another.

The drainage system also includes vents that carry odors caused by drain water and waste out of the RV, while also equalizing air pressure. Drain clean outs are provided to clean lines between fixtures and holding tanks.

DRAINAGE P-TRAPS

By code, all drains are equipped with P-traps to keep holding tank odors from entering the vehicle. If you detect a foul odor, which you believe is from your holding tanks, add water to all drains to ensure that your P-traps water hasn't evaporated from long term storage. Places to add water include the Kitchen sink, Bathroom sink, shower/tub, wet bar sink, and the washer/dryer drain.

HOLDING TANKS

Your unit has a GRAY WATER HOLDING TANK and a BLACK WATER HOLDING TANK. The tanks should be emptied frequently, or as indicated on the monitor panel. The tanks should always be emptied at a special DUMPING STATION. Most campgrounds and highway rest stops and many gasoline stations are equipped with proper DUMPING STATIONS.



NOTE: MOST STATES HAVE LAWS PROHIBITING EMPTYING SEWAGE ANYWHERE BUT AN APPROVED DUMPING STATION. THIS INCLUDES BOTH, GRAY AND BLACK WATER.

While camping, it is a normal practice to leave your GRAY WATER HOLDING TANK valve open if your campsite is equipped with sewer hook-up. NEVER leave the BLACK WATER TANK valve open while using the coach. Since the system utilizes gravity to empty, the BLACK WATER TANK will not drain properly unless it has sufficient liquid to help drain out the solids. On some models the bath lav sink drains into the black holding tank to assist with flushing. Some models may also have the shower draining into the black holding tank.

On models equipped with two gray holding tanks, you must use the dump lever for each tank to empty its contents. Pulling the dump lever for one tank WILL NOT empty the other. Each holding tank fluid level is represented on the monitor panel.

EMPTYING HOLDING TANKS



WARNING: PROPER PRECAUTIONS MUST BE UNDERTAKEN WHEN WORKING IN AN UNSANITARY ENVIRONMENT SUCH AS EMPTYING SEWAGE TANKS. PROPER GEAR (RUBBER GLOVES, SHOES, ETC.) MUST BE WORN. USE HAND SANITIZER OR OTHER PRECAUTIONS WHEN FINISHED.

To empty the holding tanks, be certain that your RV is level since this process depends upon gravity. Remove the sewage drain hose from its storage location. Remove the cap from the termination outlet and connect the drain hose (FIG. 15).

NOTE: DRAIN THE TOILET (BLACK) HOLDING TANK FIRST.

To drain either holding tank, pull out the TERMINATION VALVE (FIG. 15) by pulling out the dump valve slide handle. Close the valve after the tank has drained. Flush or pour about two gallons of water through the toilet when emptying the black tank and drain again. This flushes the tank and helps

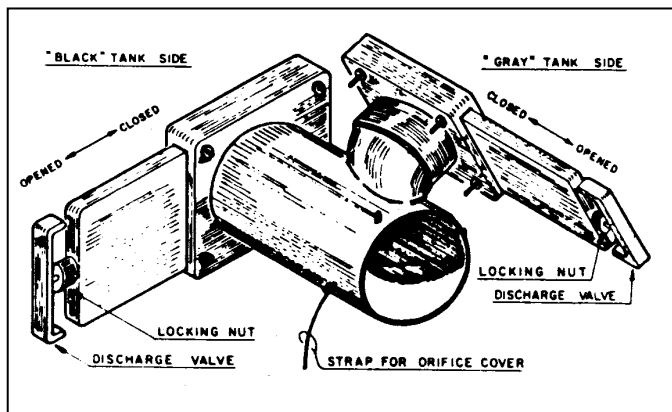

(FIG. 15) TERMINATION VALVES

clean the drain hose. Repeat as necessary. Follow the same procedure for the GRAY WATER HOLDING TANK. A repeat flush is not necessary. When the tank is empty, push the dump valve handle in until it seats. Remove the hose, wash and replace it in its storage location. Replace termination outlet cap.

HOLDING TANK MAINTENANCE

Keep your tanks well flushed out when the vehicle is not in use. Allowing the tank to sit with any contents for more than a couple of days will ensure some sort of build-up on the monitor probes in the side of the tank and future monitor reading problems, even if this is the first time you have used your RV. One way to help flush them out is to drain them at the campground, then fill each tank half full of water for the trip home. The constant agitation while driving home usually does a good job of cleaning the tanks. Then, before you arrive at home, stop at a local approved dumping station and drain the tanks completely.

When camping, there are a few things you can do to help facilitate the cleaning process later. First, you should always use some type of chemical additive in your holding tanks specifically designed for RV use. These types of chemicals will break down the contents of the tanks and help ensure good drainage. In addition, try using tissue designed for recreational vehicles. It will break down more than residential style tissues, and usually never clogs your drain valves.

DO'S AND DON'T OF HOLDING TANK USE

- DO** Clean the holding tank with an approved cleaner.
- DO** Add a special chemical additive to sanitize and improve tank action.
- DO** Guard the tank against Freeze-up.
- DO** Keep the dump valves closed to allow the tanks to get as full as possible to facilitate drainage.
- DO** Keep the dump valve closed and the drain cap in place to allow the use of the system when not parked at a campsite.
- DON'T** Put Facial tissues, paper, automotive type anti-freeze, sanitary napkins, diapers or household toilet cleaners in your holding tank.
- DON'T** Put foreign objects in the system that could clog or damage it in any way.
- DON'T** Use the toilet while driving down the road. All occupants must remain seated with a secure seatbelt while the vehicle is moving. Further, the vacuum caused by the high-speed movement of the vehicle will cause the toilet to act as a vent when flushed, causing severe odors in the vehicle and possibly spraying waste into the interior of the coach.

HOLDING TANK FLUSH SYSTEM (OPTIONAL)

The optional holding tank flush kit can be installed on the gray and black water holding tank systems. To use this system, connect a water hose to the flush kit hose located inside the holding tank dump valve compartment. Note that the lever used on this system is not an "on/off" lever, but rather a selector for which tank you wish to flush. After connecting your water hose, turn on the water to begin flushing your tank. For best results leave the dump valves closed until you have flushed each tank. Do not leave the flush system unattended, unless you decide to leave your dump valves open.

The optional glass container on the flush system hose is used to house a sanitation tablet for sanitizing each tank. Tablets are available at most RV dealers or RV parts stores.

WATER SYSTEM WINTERIZING

NOTE: READ THIS BEFORE WINTERIZING YOUR WATER SYSTEM.

If your RV is going to be stored unheated in temperatures that COULD GO BELOW FREEZING, the fresh water and waste systems must be winterized.

Follow this procedure:

1. Drain the fresh water tank.
2. Drain pipes by turning the water pump ON and opening a cold water faucet. Wait for the water flow to stop. Turn pump OFF. Leave faucets OPEN.

3. Turn ON all faucets and OPEN the HOT and COLD WATER PIPE DRAIN VALVES. Leave these valves in the OPEN position. These valves are located either under the galley sink or in an exterior compartment, and permit the water to drain onto the ground below the RV.
4. OPEN the WATER HEATER drain valve located at the bottom of the heater (or remove plug). Let the water drain out. OPEN the heater SAFETY VALVE.
5. Flush the toilet.
6. After each faucet has been opened, drained and closed, CLOSE the WATER LINE DRAIN VALVES.
7. Drain the WASTE WATER HOLDING TANK.
8. Double check that ALL WATER has been drained.
9. Secure all protective caps including the water tank filler, city water inlet and waste drain outlet.

CAUTION: DRAINING THE WATER SYSTEM ALONE MAY NOT BE ENOUGH TO PROVIDE COMPLETE COLD WEATHER PROTECTION FOR AN RV UNIT THAT WILL BE STORED IN AN UNHEATED ENVIRONMENT WHERE TEMPERATURES DROP BELOW FREEZING. CONSULT YOUR DEALER FOR MORE INFORMATION ON THE BEST METHOD OF WINTERIZING YOUR VEHICLE.

Units equipped with a winterization siphon hose should use it to pump RV anti-freeze into the plumbing system. Always pour a cupful of RV anti-freeze into each drain after your coach has been winterized.



WARNING: DO NOT USE AUTOMOTIVE ANTI-FREEZE OR WINDSHIELD WASHER FLUID ANTI-FREEZE IN THE RV POTABLE WATER SYSTEM. THESE CAN BE HARMFUL OR FATAL IF SWALLOWED. YOUR DEALER CAN PROVIDE YOU WITH SPECIAL ANTI-FREEZE THAT IS SAFE AND APPROVED FOR RV WATER SYSTEMS. ALWAYS FOLLOW MANUFACTURER'S INSTRUCTIONS FOR THESE ADDITIVES.

APPLIANCES



WARNING: THE WATER HEATER AND FURNACE USE LP GAS AS FUEL, AND IN THE COURSE OF NORMAL OPERATION HAVE PARTS/SURFACES THAT BECOME VERY HOT AND ALSO EMIT COMBUSTION GASES. BE CAREFUL TO ALWAYS FOLLOW MANUFACTURER'S RECOMMENDATIONS ON VENTILATION AND DO NOT TOUCH THE AIR EXHAUST PORTS OR ALLOW ANY MATERIAL TO COVER THEM OR EVEN COME IN CONTACT WITH EITHER THE INTAKE OR EXHAUST OF THESE APPLIANCES. WHENEVER YOU OR SOMEONE IN YOUR VEHICLE SMELLS LP GAS, IMMEDIATELY TAKE PRECAUTIONS AND VERIFY IF A LEAK IS PRESENT.

WATER HEATER

NEVER IGNITE THE HOT WATER HEATER WITHOUT FIRST FILLING IT WITH WATER! FAILURE TO FOLLOW THIS PROCEDURE MAY PERMANENTLY DAMAGE YOUR WATER HEATER.

The water heater is accessed by a panel on the outside of the vehicle (FIG. 16). Turn on the hot water faucet at the galley sink to see if the tank is full. Operating instructions can be found in the water heater owner's manual.



WARNING: ONLY QUALIFIED TECHNICIANS SHOULD PERFORM SERVICE ON THE WATER HEATER. IF NOT SERVICED PROPERLY, A FIRE COULD OCCUR.

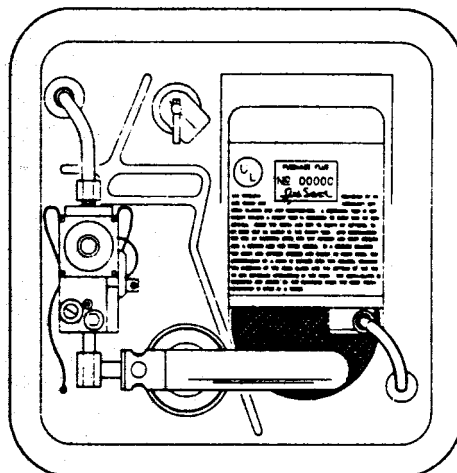

(FIG. 16) WATER HEATER

RANGE

Also operated with LP gas are the range burners and the oven (optional). The basic operation is the same as the units in your home except that extra care must be taken to provide adequate ventilation in your RV. Unlike your home, the RV has limited air space, thus, a limited amount of oxygen available for combustion.



WARNING: DO NOT USE OPEN FLAMES, SUCH AS THE RANGE BURNERS, TO WARM THE LIVING AREA OF THE RV. THE FLAMES CONSUME THE OXYGEN IN THE VEHICLE AND COULD RESULT IN ASPHYXIATION.

Always provide adequate ventilation when using the range and oven. It is always best to use the range exhaust hood and open a window slightly.

Your owner's packet contains owner's manuals for the range and optional oven. Read these over carefully to become familiar with the safe operation of these appliances.

MICROWAVE

The optional microwave is no different than that found in your home. It relies on 110-volt power for operation. Read over the microwave oven's owner's manual to find all the information on its operation and cleaning. Due to the limited amount of electrical power commonly found in RV's, you may not be able to use your microwave unless other electronic devices with a heavy electrical load (air conditioners) are first turned off. Please refer to the 30 amp and 50 amp 110 volt section of this manual for more information on electrical loads.

REFRIGERATOR

Unlike your home refrigerator, the unit on your RV can be operated on LP gas and 120-volt AC electricity. Read over the owner's manual provided in your owner's packet before putting the refrigerator into operation.

The refrigerator will not operate correctly if the vehicle is not level while parked. The refrigerator coolant will not circulate properly if the unit is not level.

For best results, make sure the outside sidewall vent and roof vent are always clear of debris. Without proper circulation of the rear coils the unit will not keep food cold.

Upon initial operation, or after being stored, the refrigerator it could take up to 24 hours before the unit is cool enough for use.

When being used on the 110 AC setting, the refrigerator circuit board still requires 12 volt operation. Make sure your batteries have sufficient charge prior to operation.

FURNACE

Your RV is equipped with a forced-air furnace similar to the type found in most homes with the exception that it is fueled by LP gas. Each unit is equipped with a wall mounted thermostat that controls the temperature. An operating manual for the furnace is included in your owner's packet.

The furnace is designed to have un-obstructed airflow from all its vents, including interior and exterior. If any vent is blocked the furnace may shut itself off.

The furnace igniter is powered by your 12-volt battery system. If the system battery is low the furnace blower will come on, however the furnace will not ignite. Make sure you have sufficient battery power before operating the furnace.

Your furnace is designed to sustain a desired temperature in the vehicle at most times. Due to varying weather conditions, the furnace may not be able to keep up with sub-freezing temperatures. The amount of vehicle occupants and the position the vehicle is parked may help or hinder the furnace's ability to keep up with freeze conditions. Consult the furnace owner's manual for more information.



WARNING: DO NOT SUPPLEMENT THE FURNACE WITH ANY PORTABLE FUEL-BURNING APPLIANCE FOR HEATING THE INTERIOR OF THE RV. THESE APPLIANCES ARE NOT SAFE; ASPHYXIATION/CARBON MONOXIDE POISONING IS POSSIBLE IN ANY SMALL, WELL-SEALED SPACE.

AIR CONDITIONER

Thoroughly read the owner's manual supplied by the air conditioner manufacturer for proper use, care and maintenance of the roof mounted air conditioner. Air conditioners are capable of cooling air a maximum of 18 to 22 degrees in a 50% humidity environment. As the humidity goes up, the cooling difference goes down. If the temperature inside your coach is 100 degrees when you turn on the air conditioner, it will only put out 80 degrees. Eventually the air inside the coach will cool, and as it cools the air put out by the air conditioner will also cool. However, when starting out at 100 degrees, this cooling could take several hours before it reaches your desired temperature. Therefore, if you know the weather will be hot, turn your air conditioner on early.

The two most common complaints with roof air conditioners are they won't turn on at all, or when they do turn on, they won't put out cold air. Obviously, if the unit won't turn on you may have a problem with something other than the air conditioner. Always make sure you have sufficient power to run each air conditioner you plan on using. If your power source has only 30-amp service, you can run only one (1) air conditioner at a time. Using an adapter to plug in your 50-amp cord to 30-amp service doesn't allow the use of both AC's either. Most AC's require a minimum of 13 amps to operate properly. Although the amperage of two AC's running at the same time doesn't add up to 30 amps, other components in the coach, such as the converter, refrigerator, VCR (draws amps simply by just being plugged in), etc., draw enough amperage to push the total amp load over the 30 amp mark. If you desire to run both AC's in a 30-amp environment, try running your generator instead of using shore power. Run both AC's off the generator until the coach cools off, then use shore power to run only one AC, which by itself will usually maintain a cool temperature inside the coach.



CAUTION: THE USE OF EXTENSION CORDS, "CHEATER" CORDS OR ADAPTORS TO REDUCE THE SIZE OF THE RECEPTACLE BEING USED TO PLUG IN YOUR RV WILL CAUSE EXCESS AMPERAGE AND STRAIN ON YOUR RV ELECTRICAL SYSTEM. THIS MAY RESULT IN TRIPPING BREAKERS, PREMATURE FAILURE OF 110-VOLT AC APPLIANCES, HOT OR MELTING CORD CONNECTIONS, OR FIRE. ALWAYS PLUG YOUR SHORE POWER INTO A POWER SUPPLY PROPERLY RATED FOR YOUR RV (30 or 50 amp service).

ROOF EXHAUST FAN OPERATION

The ceiling fan used in your coach is designed to ventilate the interior when cooking or if the use of your air conditioner is not desired. If used properly the roof fan can cool the interior by as much as 15 degrees within a short period of time. When used in the exhaust mode, the fan pulls hot air from high inside the coach and will pull fresh air from an open window. This fan is usually controlled by a wall-mounted thermostat (some models have a thermostat built right on the fan), which must be turned on and adjusted to your desired temperature before use. The wall-mounted thermostat is not the same that is used for the furnace or air conditioners. Please review the supplied fan owner's manual for additional operating instructions.

Effects of Long Term Occupancy

FORMALDEHYDE

If you notice an odor in your recreational vehicle – it could be formaldehyde

Gulf Stream is an industry leader in reducing emissions of formaldehyde from the products used in constructing its RV's.

Formaldehyde is commonly found in nearly all homes and buildings. It is a colorless gas that is released into the home from a variety of indoor sources. Formaldehyde can be found in a variety of everyday products in your home, such as:

Household Products: cleaning solutions, dishwashing liquids, fabric softeners, shoe-care agents, carpet cleaning solutions, adhesives

Personal Care Products: nail polish, cosmetics, shampoos, antiperspirants

Fabrics: clothing, linens, draperies

Appliances: gas appliances, kerosene stoves

Tobacco Products: cigarettes, cigars

Building Materials: particleboard, plywood cabinets, and wall and floor materials, wallpaper, some other paper goods, paint coatings

As a result, **recreational vehicles**, mobile homes, manufactured homes, new homes, and recently remodeled homes are more likely to contain higher levels of formaldehyde. Over time, formaldehyde goes away and the odors and the effects decrease or disappear.

What can I do to reduce my exposure to formaldehyde in my recreational vehicle?

- **Increase ventilation.** Adequate ventilation normally reduces or eliminates any or all of the above stated symptoms. Always be sure to ventilate your recreational vehicle prior to and during use, especially after storage and during hot, humid weather. We recommend opening windows and running ventilation fans as much as possible during the initial break-in period.
- **Keep indoor temperatures moderate.** As the temperature rises, the effects of formaldehyde may be more noticeable. You can use the air conditioner to keep temperatures relatively low, which will help lower the formaldehyde effects and odors.
- **Lower the humidity.** You can decrease the rate at which formaldehyde is released from pressed wood and other products by lowering the humidity in your recreational vehicle. Humidity should be maintained at about 40% to 50% relative humidity in the home.
- **Do not smoke inside.** Tobacco smoking produces formaldehyde and other toxic chemicals.



WARNING: ALL RECREATIONAL VEHICLES ARE BUILT WITH SOME MATERIALS THAT EMIT FORMALDEHYDE. EYE, NOSE AND THROAT IRRITATIONS, HEADACHE, NAUSEA AND A VARIETY OF ASTHMA-LIKE SYMPTOMS, INCLUDING SHORTNESS OF BREATH, HAVE BEEN REPORTED AS A RESULT OF FORMALDEHYDE EXPOSURE. ELDERLY PERSONS AND YOUNG CHILDREN, AS WELL AS ANYONE WITH A HISTORY OF ASTHMA, ALLERGIES, OR LUNG PROBLEMS MAY BE AT GREATER RISK. RESEARCH IS CONTINUING ON THE POSSIBLE LONG-TERM EFFECTS OF EXPOSURE TO FORMALDEHYDE.

If you have questions regarding the health effects of formaldehyde, consult your doctor or local health department. Adequate ventilation normally reduces or eliminates any or all of the above problems. Always be sure to ventilate your RV prior to and during use, especially after storage and during hot, humid weather. Generally, levels of formaldehyde emitted diminish over time.

“FULL-TIME” USE

Accelerated wear and tear can be expected from “full-time” use of this product, as this product is designed for recreational camping. Wear and tear issues cannot be considered under any factory assistance program.

CONDENSATION AND MOLD

If you that intend to use this RV for extended periods of time, you must be prepared to deal with condensation and the humid conditions that may be encountered. The normal activities of even a small number of occupants in the relatively small volume of a modern recreational vehicle and its tight construction, will lead to rapid saturation of the air inside the vehicle and the appearance of visible moisture on walls and glass, especially during cold weather.

Estimates indicate that a family of four can vaporize up to three gallons of water daily through its breathing, cooking, bathing and washing. Unless this vapor is carried outside by ventilation, or removed from the air by a dehumidifier, it will condense on the inside of the windows and walls as moisture. In cold weather it will appear as frost or ice. It may also condense in the walls or ceiling and appear as stains on paneling. This will increase the heating load on the furnace somewhat, but it will greatly reduce condensation. You should increase ventilation when large numbers of people are present.



WARNING: RECREATIONAL VEHICLES ARE SUBJECTED TO BEING CLOSED UP FOR LONG PERIODS OF TIME, WHICH CAN RESULT IN EXCESSIVE HUMIDITY, AN AVERAGE CONDITION THAT CAN LEAD TO THE FORMING OF MOLD. IF MOISTURE PENETRATION OCCURS, IT IS ABSOLUTELY IMPERATIVE TO HAVE IT REPAIRED TO AVOID DETERIORATION OF MATERIALS AND THE ENVIRONMENT THROUGH THE INTRODUCTION OF MOLD OR BACTERIA. MOLD AND BACTERIA ARE ALWAYS PRESENT IN A HABITAT.



WARNING: DO NOT USE COOKING APPLIANCES FOR COMFORT HEATING. IN ADDITION TO THE TOXIC FUMES AND OXYGEN DEPLETION, OPEN FLAMES ADD MOISTURE TO THE AIR INCREASING CONDENSATION AND THE POSSIBILITY OF MOLD.

SLIDE OUT SYSTEMS

If your vehicle is equipped with a slide out there are several precautions that should be taken before operation of the slide room.

1. Make sure you have clearance on the exterior.
2. Make sure that all interior items are clear.
3. Make sure that you have sufficient battery power.

SLIDE OUT SYSTEMS OWNER’S MANUALS AND TROUBLESHOOTING GUIDES

Gulf Stream products carry a variety of electrically operated slide out products. The electrical slide out product installed in your particular RV is accompanied by an owner’s manual from the slide out system manufacturer. For troubleshooting, maintenance and proper use of your particular slide out, please refer to the slide out owner’s manual supplied by the slide out system manufacturer. Most slide out system owner’s manuals and troubleshooting guides can also be found on the slide out system manufacturers websites.

SLIDE OUT WEATHER SEALS

Periodically check all seals and gaskets on the slide out walls for proper fit and operation. Check the condition of the slide tubes (not the hydraulic ram) under the slide out, and if needed use bearing grease for ease of operation.

Slide outs are not designed to have a 100% air-tight seal. However, you will find that the best seal possible can be achieved with pro-active maintenance and proper use. Occasional adjustment of the slide out room to prevent water or air intrusion may be necessary under normal operation. With normal adjustments, the slide out may not appear to be perfectly level within the slide out opening of the RV sidewall. This is a normal occurrence. Further, slide out adjustments may result in decal or paint line alignment concerns. The failure of paint or decals to line up after slide out adjustments does not require attention and repainting or applying new decals is not necessary or covered under the Gulf Stream Coach, Inc. Limited Warranty.

AWNINGS

Electric awnings installed on your RV are optional and/or may have been added by your dealer. Proper use, care, and maintenance procedures for awnings are included in the literature provided with the awning.



WARNING: SOME AWNINGS CONTAIN PINCH POINTS, WHICH IF USED IMPROPERLY CAN CAUSE INJURY. PLEASE READ AND UNDERSTAND ALL OPERATOR INSTRUCTIONS INCLUDED WITH YOUR AWNING(S) PRIOR TO USE OF THE PRODUCT.

MANUAL AWNINGS

To open your main awning:

- Make sure that you have sufficient clearance from obstructions.
- Unlock the awning using the provided wand by pulling down the locking latch located on the top of the right awning arm.
- Unlock the travel lock on the awning arm, if equipped.
- Loosen the rafter arm knobs located in each awning arm.
- Using the wand, hook the loop hanging in the center of the awning and pull the awning completely out.
- Slide each rafter arm to the top of each awning arm and tighten the rafter knobs, making sure the awning fabric is not loose.
- Near the base of each awning arm is a flip-out lever/handle, which is also an awning arm slide lock. When the lever is flipped out, the awning arm can be slid up to raise the awning. Flipping the lever back down will allow the arm to lock.
- Your awning is now in place. You may choose to use anchor straps for extra support in windy conditions.

To close the main awning:

- Flip the awning arm levers out and slide the awning arms back down, being careful not to let the awning drop down, as flipping the levers out will unlock the arm and allow it to slide down.
- Loosen the rafter arm knobs and slide the rafter arm as far down as it will go. Do not re-tighten the rafter arm knobs as this time.
- While holding the wand strap in the awning tube, push the awning main latch located on the top of the right arm to "locked." BE CAREFUL! This will cause the awning to roll up if you don't have a good hold of the awning tube strap.
- Holding the awning tube strap, allow the awning to roll up until you can use the wand in the strap. Using the wand, allow the awning to roll all the way up. Do not allow the strap to get rolled all the way in the awning fabric.
- Lock the awning arm travel latches.
- Re-tighten the rafter arm knobs located in each awning arm.

MAINTENANCE

ROOF

If you decide to access the roof via the rear mounted ladder, we recommend that you stay low and/or near the middle of the roof. When accessing the roof, use extreme caution and avoid movement on areas near the roof air conditioner ducting (some models) and/or between the rafters on light (lite) models. While it is ok to apply pressure in these areas and a slight dipping may be visible, this does not indicate a structural problem with the roof. Use of plywood to displace your weight on the roof may be required on some lighter weight models. Generally, the roof should be checked at least twice a year. If you find any area that looks questionable, reseal it. The sealant that you should use depends on what type has already been applied. It may be necessary to remove all sealant in the questionable area prior to resealing, as this will ensure the new sealant is effective when properly applied.



WARNING! ACCESS TO THE ROOF IS FOR MAINTENANCE ONLY. THE ROOF IS NOT DESIGNED FOR RECREATIONAL USE. FURTHER, THE ROOF IS NOT EQUIPPED WITH SAFETY RAILING FOR RECREATIONAL USE. DO NOT ACCESS THE ROOF IF: WET, ICY OR SLIPPERY CONDITIONS ARE PRESENT, THE VEHICLE IS UNSTABLE OR SUBJECT TO MOVEMENT, WINDY CONDITIONS ARE PRESENT, OR ANY OTHER SITUATION THAT RENDERS ROOF ACCESS UNSAFE.

RUBBER ROOF REPAIR

Small tears or punctures in the rubber roof membrane can easily be repaired and will have the same life span as the rest of the rubber roof. Most RV dealers carry rubber roof repair kits at a very nominal price. Please refer to your specific repair kit for proper applications

ALUMINUM EXTERIOR SKIN

Use a mild soap in cold or lukewarm water to wash dust, dirt, road tar, insects, and other foreign matter from the exterior surfaces. To avoid marring body surfaces, do not press down hard on the siding when washing, do not use abrasive cleaning compounds or cloths, and do not wipe the surface with a dry cloth.

Check all sealants when washing or at least two (2) times a year, whichever is more frequent.

In warmer climates some normal expansion of the aluminum siding may occur, causing slight protrusions of the skin. Do not attempt to press down on the skin to correct this normal condition

SIDEWALL TRIM AND COMPONENT SEALANTS

Other areas that will need attention include the moldings used on the side walls and the compartment door edge moldings. Since these areas are more accessible for periodical checks, It is recommended to inspect the side walls and compartment doors every time you wash your vehicle. Sometimes washing the side walls can actually remove some necessary sealants. If you find an area on your side walls that needs resealed, a clear silicone, or one that matches the color of your side walls should be used. When resealing compartment doors, only a clear silicone sealant is recommended, as these doors are usually painted and the color would be difficult to match.

The last few areas that might need attention are those around the clearance lights, tail lights, rear view mirrors, and around accessories and windows. All these areas can be resealed using a common silicone based sealant/adhesive. However, when sealing windows and the base of rear view mirrors, be careful as to keep from sealing over any weep holes. These holes are designed to drain any water that may have found its way to the inside of a window or mirror.

Keeping up on the maintenance of your sealants will keep your RV looking beautiful for a long time. If you are not sure what types of sealants should be used on any part of your RV, a simple phone call to your local dealer for direction will prove beneficial.

PAINT, FIBERGLASS, AND SIDEWALL CARE

The sidewalls of your RV have a combination of fiberglass, paint and vinyl decals. The proper care and maintenance of each one of these elements is crucial in the longevity of your vehicle's proper appearance. If you plan on using wax on your side walls you should use a marine type wax on the unpainted portions of the coach. Marine type wax is best suited for fiberglass surfaces. Regular automotive wax is suitable for painted surfaces of the RV.

Avoid storing your RV in the same spot facing the same direction for extended periods of time! The sun can literally bake the finish off of your RV if it is not properly rotated during prolonged use and/or storage.

CORROSION PROTECTION

Your Gulf Stream recreational vehicle has been designed to withstand normal environmental conditions. But, the sand and salt used on the highways and the salt spray in the air near oceans can cause the metal components on your recreational vehicle to corrode.

To protect your recreational vehicle from this corrosion, it must be thoroughly cleaned as soon as possible after exposure to these elements. Washing the undercarriage with a high-pressure washer will remove the majority of the salt. But, this will not replace the paint that is literally sand-blasted off the undercarriage by the road salt and sand. Sand-blasted and corroded frame components must be refinished. This can be done with readily available rust preventative paint and undercoating. This is necessary to properly maintain your recreational vehicle.

We have also found generators to be affected by salt spray. Since the generator requires air for operation and cooling, the generator compartment cannot be completely sealed from the elements. Therefore, whenever the recreational vehicle is exposed to salt spray, the generator should also be cleaned.

Aftermarket undercoating processes are also beneficial in rust prevention. But, to remain effective, these treatments must be inspected and renewed annually as most undercoating agents can dry and peel with age.

Therefore, regularly scheduled inspections and maintenance is necessary to protect your recreational vehicle and its various components and fixtures from the elements and keep it corrosion-free.

In addition to maintenance, you should keep from storing your vehicle in grassy areas for long periods of time. The stagnant, moist air developed under the coach will speed up the corrosion process. Always store your vehicle on pebble, concrete or asphalt.

Some components used by Gulf Stream and the chassis manufacturer, by nature, will appear to be "rusty" or corroded on the surface. These components are not required to be rust free for normal operation. These components may include axle housings, brake caliper housings, LP black pipe fittings, etc.

AWNING CARE

Be sure to clean off all debris as you roll up your awnings. Periodically wash off the awning fabric with a soapy water solution. Long term exposure to the sun may cause some fading over time, which is normal. Harsh exposure can cause the awning fabric to delaminate.

REPORTING SAFETY DEFECTS

If you believe that your vehicle has a defect which could cause a crash or could cause injury or death, you should immediately inform the National Highway Traffic Safety Administration (NHTSA) in addition to notifying Gulf Stream Coach, Inc.

If NHTSA receives similar complaints, it may open an investigation, and if it finds that a safety defect exists in a group of vehicles, it may order a recall and remedy campaign. However, NHTSA cannot become involved in individual problems between you, your dealer, or GULF STREAM COACH, INC.

To contact NHTSA, you may either call the Auto Safety Hotline toll-free at 1.800.424.9393 or write to : NHTSA, U.S. Department of Transportation, Washington, D.C. 20590 or at www.NHTSA.gov. You can also obtain other information about motor vehicle safety from the hotline.

PRE-TRIP CHECK LIST (AT HOME)

EXTERIOR

All objects secure..... _____
Tires at proper pressure (spare)..... _____
(Check for wear and damage)
Hitch and hitch ball secure..... _____
Stabilizers raised..... _____
Brakes checked for operation..... _____
Under-carriage items secure..... _____

Awnings locked..... _____
Wheel lug nuts at proper torque..... _____
All exterior lights operational..... _____
Batteries charged, fluid level okay..... _____
Secure all compartment doors..... _____
Roof items secure..... _____

INTERIOR

Antenna lowered..... _____
Refrigerator locked..... _____
Water pump OFF..... _____
Waste water tank levels..... _____
Furnace OFF..... _____
Cooktop Cover CLOSED..... _____

Roof vents lowered..... _____
Water heater OFF..... _____
Fresh water tank level..... _____
Toilet operational..... _____
LP Gas System checked..... _____
Drawers, Closets, Windows CLOSED... _____

PRE-TRIP CHECK LIST (CAMPSITE)

FOLLOW THE ABOVE CHECK LIST WITH THESE ADDED POINTS:

EXTERIOR

Disconnect all shore lines..... _____
(City water, electric, sewer, cable)
Retract step..... _____
Store camping equipment..... _____

Remove wheel chocks..... _____
Retract Stabilizers..... _____

CHECK CLEARANCES PRIOR TO PULLING OUT

This check list may seem like it contains basic items, but many are taken for granted and can spoil a camping trip if not attended to prior to moving the vehicle. You may want to use this list as a start for your own Pre-Trip check list, which may include your personal camping gear and food preferences.

MAINTENANCE SCHEDULE

	INSPECT/TEST BEFORE EACH TRIP	MONTHLY	EVERY 3 MONTHS	EVERY 6 MONTHS OR 3,500 MILES*	YEARLY OR 7,000 MILES*	AS REQUIRED BY MANUFACTURER
(*WHICHEVER OCCURS FIRST)						
AXLE AND SPRINGS	X				X	
BATTERIES	X			X		
BRAKES	X				X	
EXTERIOR LIGHTING	X				X	
FRESH WATER SYSTEM					X	
HAVE ALL APPLIANCES SERVICED						X
LP GAS SYSTEM					X	
PIGTAIL CONNECTION	X				X	
ROOF SEALANT				X		
ROOF VENTS			X	X		
SAFETY BREAKAWAY SWITCH OPERATION	X				X	
SAFETY CHAIN CONNECTION	X					
SIDEWALL SEALANTS			X	X		
TIRE LUG NUTS (AFTER INITIAL 500 MILE CHECK)	X					
TIRES (CONDITION AND PRESSURE	X					
UNDERBELLY, CHECK FOR TEARS OR LEAKS				X		
WHEEL BEARINGS					X	
WINDOW SEALANT		X		X		

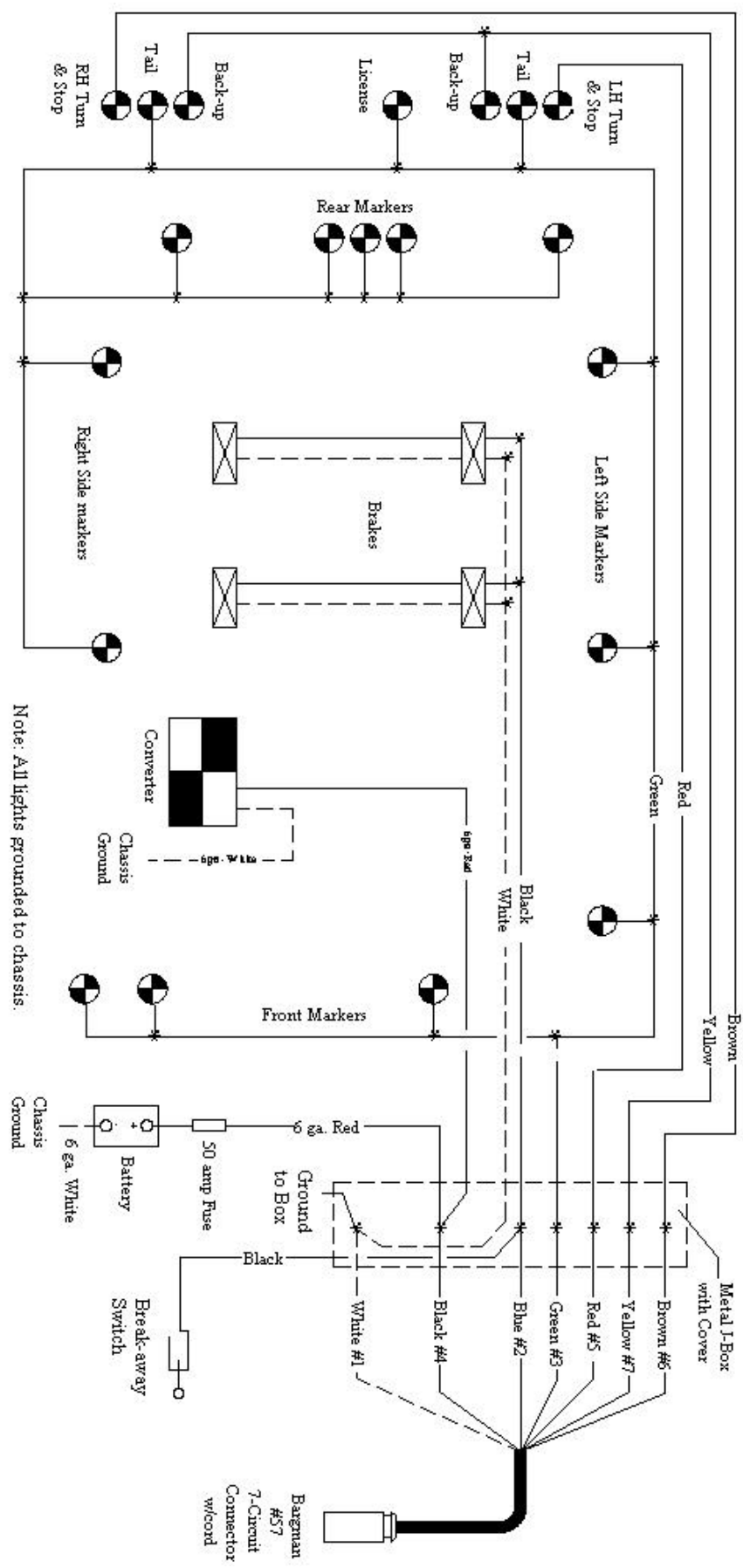

Note: All lights grounded to chassis.

INDEX

12-VOLT/110-VOLT..... 19

A

AIR CONDITIONER 32
 APPLIANCES..... 30
 AWNINGS..... 35

B

BATTERY TYPES AND CHARGING..... 22
 BRAKE CONTROLLER..... 9

C

CARBON MONOXIDE SAFETY..... 8
 CITY WATER..... 26
 COMPONENT WARRANTY COVERAGE..... 6
 CORROSION PROTECTION..... 37

D

DRAINAGE AND SEWER..... 27

E

EFFECTS OF LONG TERM OCCUPANCY..... 33
 ELECTRIC BRAKE SYSTEM..... 18
 ELECTRICAL..... 19

F

FANTASTIC FAN OPERATION..... 32
 FIRE SAFETY..... 8
 FRESH WATER..... 25

G

GAS LINE CHECK (LP)..... 24
 GROUND FAULT INTERRUPTER..... 21

H

HITCH – FIFTH WHEEL HEIGHT ADJUSTMENT..... 12
 HITCH LOCKING DEVICES..... 10
 HITCHING – TRAVEL TRAILERS..... 9
 HOLDING TANK MAINTENANCE..... 29
 HOSE REPLACEMENT (LP)..... 25

L

LOADING TIPS..... 13
 LP REGULATOR PRESSURE..... 25
 LP GAS..... 25

M

MAINTENANCE..... 36, 39
 MICROWAVE..... 31

P

PLUMBING..... 25
 PRE-TRIP CHECK LIST..... 38

30-AMP AND 50-AMP 110-VOLT SERVICE..... 19

ANTENNA – TV..... 23
 AWNING CARE..... 37

BATTERY..... 21

CARRYING CAPACITY..... 13
 CLIMATE DIFFERENCES (LP)..... 24
 CONDENSATION AND MOLD..... 34

DRAINAGE P-TRAPS..... 28

ELECTRIC AWNINGS..... 35
 ELECTRIC TRAILER CORD CONNECTION..... 12
 EQUALIZING HITCHES..... 9

FEDERAL WEIGHT DEFINITIONS..... 16
 FORMALDEHYDE..... 33
 FURNACE..... 31

GAS TANK AND REGULATOR FREEZE UP (LP)..... 25
 GULF STREAMERS INTERNATIONAL RV CLUB..... 43

HITCH – TRAVEL TRAILER HEIGHT ADJUSTMENT..... 11
 HITCHING – FIFTH WHEELS..... 11
 HOLDING TANK FLUSH SYSTEM..... 29
 HOLDING TANKS..... 28

LP GAS LINE CHECK..... 24
 LP GAS SAFETY..... 7, 9
 LP TANK – FILLING..... 24

MANUFACTURERS LABELS..... 15
 MONITOR PANEL..... 22

POWER CONVERTER..... 20

R

RANGE..... 31
REPORTING SAFETY DEFECTS..... 37
RUBBER ROOF REPAIR..... 36

S

SAFETY.....8, 23
SAFETY CHAINS..... 10
SLIDE OUTS SYSTEMS..... 34
SWAY CONTROL..... 10

T

TIRES..... 16
TIRE LOAD RATINGS..... 17
TIRE MARKINGS..... 14
TOW VEHICLE REQUIREMENTS..... 9

U

V

VEHICLE LOADING..... 13

W

WARRANTY – GULF STREAM..... 4
WATER HEATER..... 30
WATER SYSTEMS CONVENIENCE CENTER..... 26
WATER SYSTEM WINTERIZING..... 29
WEIGHING – FIFTH WHEELS..... 15
WINTERIZING THE WATER PUMP..... 27

REFRIGERATOR.....31
ROOF.....36

SAFETY BREAKAWAY SWITCH.....10, 12
SANITIZING THE WATER TANK..... 26
SMOKE DETECTOR..... 8

TIRE AIR PRESSURE..... 17
TIRE MAINTENANCE..... 17
TIRES..... 14
TRAILER LIGHT SCHEMATIC.....40

VEHICLE WEIGHT INFORMATION LABEL..... 16

WATER PUMP..... 27
WATER TANK..... 26
WEIGHING – TRAVEL TRAILERS..... 14



1. **Active Chapters:** Members are encouraged to join and participate in their local chapter activities. If there is not one in your state, we will help you promote the club to get a chapter started. For more details, contact the International Office. Chapter Officers receive free membership to the International Club.
2. **Magazine:** Main Stream is issued quarterly to keep you informed of upcoming International events, local chapter happenings and Gulf Stream product and service updates.
3. **Fellowship and Friendship:** RVers are a special breed! The Gulf Streamers club will give you a chance to meet many who share this wonderful pastime.
4. **International Rallies and Caravans:** Professionally scouted and pre-planned International Rallies and Caravans with experienced wagonmasters to help make your trip trouble free and more enjoyable.
5. **Promotional Items:** Offered only to members of the Gulf Streamers club at special discount prices.
6. **Web site:** Updated frequently with new events, pictures, newsletters and Gulf Streamer chapter articles. All the latest information can be found at our club website: streamers.gulfstreamcoach.com
7. **Gulf Stream Country Club:** Open Memorial Day – Labor Day. This 55-acre complex includes a nine-hole par-3 golf course, shuffleboards, basketball/tennis courts, swimming pool and more.
8. **Streamwear by Gulf Stream:** As a member of the Gulf Streamers, you have the opportunity to order hats, jackets, and shirts with the Gulf Streamers logo. Attractive apparel offered at special club prices.
9. **Discounted Parts:** 10% discount offered to all active club members on all parts ordered through any authorized service center. Must provide service center with membership number. Call (800) 482-6456 or click on Dealer Locator on our website (www.gulfstreamrv.com) to find your nearest Gulf Stream authorized service center. If dealer is new, dealer may need to verify program with Gulf Stream for clarification by calling (800) 289-8787 ext. 3067 or 3664.
10. **Discounts:** Members receive discounts on National Theme Parks and special attractions. You also receive special rates on RV and travel guides, directories and magazines.
11. **Hertz-Discount Card:** As a member you receive special car rental rates, discounts and program enhancements such as weekly rental discounts and free car class upgrades.
12. **Passport America:** Free one year membership to the "Original" 50 % discount camping club. Does not include shipping and handling and is only available to new members.
13. **Flying J Membership:** Receive up to 30 cents off per gallon on gasoline and propane! Enjoy special RV fuel islands, free RV dump stations, free audio adventures membership, and receive exclusive E-coupons when you provide Flying J with a valid email address.
14. ***Gulf Streamers RV Insurance:** (Offered through Farm and City Insurance) An outstanding opportunity that offers members full coverage at competitive prices. Policies cover both full and part-time RVers at special rates, including diminishing deductibles.
15. ***Gulf Streamers Emergency Road Service:** (Offered through Coach Net) An opportunity to receive 100% paid road service, no limit towing, fuel delivery and many other benefits at special prices. Exclusively available for the Gulf Streamers International RV Club.
16. ***RVMCA Mail Forwarding and Voice Mail Service:** Participate in one of the most comprehensive, cost-efficient mail forwarding services available. Low one-time enrollment fee with no annual dues. Various packages available call (866) go-RVMCA.
17. ***SkyMed International:** (Offered through SkyMed International) Emergency air evacuation membership plans.

*Optional

Membership Application (Please Print)

Name _____
 Address _____
 ZIP _____ Phone _____
 Cell Phone _____
 E-mail: _____
 Anniversary Date _____

Spouse _____
 City _____ St./Prov. _____
 Check One: Membership Dues Renewal/Reinstatements
 _____ One Year (\$25) _____ One Year (\$20)
 _____ Two Years (\$40) _____ Two Year (\$35)
 _____ Three Years (\$50) _____ Three Years (\$45)

Model _____ Year _____
 Membership Sponsored by _____

Unit Serial # _____
 Sponsor Membership # _____

(Not necessary for membership)

Check or Money Order (in U.S. Funds) **VISA** CARD # _____ Exp. Date ____/____
 Payable to: Gulf Streamers Int'l RV Club  Signature _____ Date _____
 Name as Appears on Card _____

Complete this application for membership and mail with your check or money order to:
 Gulf Streamers International RV Club, P.O. Box 1005, Nappanee, IN, 46550 or phone (800) 289-8787 ext. 3067.

Membership dues are non-refundable.
Membership in the Gulf Streamers is limited to owners of Gulf Stream recreational vehicles.